



TABLE OF CONTENTS

1	Introduction		5
2	System Overview		15
3	Operation overview		37
4	Displaying and saving data		45
5	Ventilation modes		55
6	Ventilatory settings and functions		83
7	Alarm handling		109
8	Service & Settings		123
9	Technical data		131
10	Index		159

1 Introduction

Table of contents

1.1	Device description		6
1.2	Safety guidelines		8
1.3	Version and configurations		14

1.1 Device description

1.1.1 Device components

The ventilator system consists of:

1. a user interface for setting ventilation modes, displaying data and indicating alarms
2. a patient unit for mixing gases and controlling gas delivery
3. a patient circuit for delivering and exchanging gases

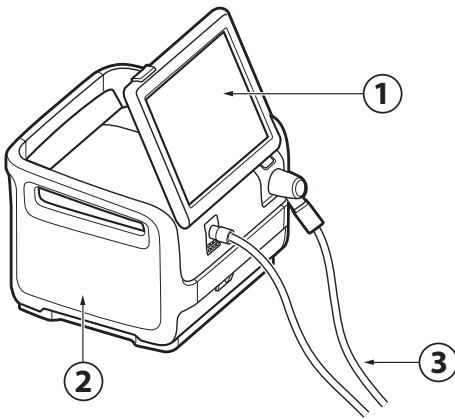

1.1.2 Intended use

The SERVO-air ventilator system is:

- intended for respiratory support, monitoring and treatment of pediatric and adult patients
- to be used only by healthcare providers
- to be used only in professional healthcare facilities and for transport within these facilities

1.1.3 User's Manual

This manual summarizes the functions and safety features of the ventilator system. It is not all-inclusive and should not be seen as a substitute for training.

1.1.4 Cleaning & Maintenance

Please refer to the SERVO-air Cleaning and Maintenance User's Manual.

1.1.5 Servicing Guidelines

CAUTIONS:

- **Regular service:** The ventilator system must be serviced at regular intervals by Maquet authorized personnel who have received specialized training.
- **Complete service records:** All service performed on the ventilator system must be recorded in a service log in accordance with hospital procedures and local and national regulations.
- **Service contract:** It is strongly recommended that all service on the ventilator system should be performed as part of a service contract with Maquet.

Note: If the ventilator system is to be a part of another system it requires an evaluation of the requirements of the IEC 60601-1 standard.

1.1.6 Disclaimers

Non-professional servicing:

Maquet has no responsibility for the safe operation of the ventilator system if installation, service or repairs are performed by persons other than Maquet authorized personnel.

1.2 Safety guidelines

Follow these safety guidelines. Additional warnings appear in context throughout this document.

Information is highlighted with Warning, Caution, Important or Note, where:

WARNING! Indicates critical information about a potential serious outcome to the patient or the user.

CAUTION: Indicates instructions that must be followed in order to ensure the proper operation of the equipment.

Important: Indicates information intended as help to operate the equipment or its connected devices easily and conveniently.

Note: Indicates information requiring special attention.

1.2.1 General

WARNINGS!

- The ventilator system may be operated only by authorized personnel who are properly trained in its use. It must be operated according to the instructions in this User's Manual.
- After unpacking, perform a routine cleaning and a pre-use check.
- Always perform a pre-use check before connecting the ventilator system to a patient.
- Secure all tubing and cables to avoid the risk of unwanted movement of the equipment.
- If any of the following occurs, discontinue use of the ventilator system and contact a service technician:
 - unfamiliar pop-up windows on the screen
 - unfamiliar sounds
 - any unfamiliar or unexplained event
 - alarms that cannot be resolved
- Make sure that a resuscitator is readily available.
- The air inlet must not be occluded.
- Positive pressure ventilation can be associated with the following adverse events: barotrauma, hypoventilation, hyperventilation or circulatory impairment.
- Ventilation must be started manually when a patient is connected to the ventilator system.
- Keep the ventilator system upright during use.

- Do not cover the ventilator system in any way, since the functioning of the equipment may be adversely affected.
- Do not modify or remove any original parts.
- The ventilator system must not be used during radiotherapy, since this may cause system malfunction.
- The ventilator system must not be used in a hyperbaric chamber.
- The ventilator system must be kept away from magnetic resonance imaging (MRI) equipment.
- The ventilator system must not be used with helium or any gas mixture containing helium.
- When the ventilator system is used with MCare Remote Services, use only network equipment that is safe and complies with the relevant electrical and EMC standards such as IEC 60950.
Note: The network cable is excluded from this requirement.
- Only accessories, supplies, and auxiliary equipment recommended by Maquet should be used with the ventilator system. Use of any other accessories, spare parts or auxiliary equipment may cause degraded system performance and safety.
- Use only the Maquet approved active humidifiers. Use of non-approved active humidifiers may result in higher gas temperatures and increase resistance in filters.
- During humidification, carefully monitor the airway pressure. Increased airway pressure could result from a clogged

filter. Replace the filter if the expiratory resistance increases or according to the instructions for the filter, whichever comes first.

- Service, repair and installation may only be performed by Maquet authorized personnel.
- The ambient sound needs to be taken into consideration when setting the alarm sound level.
- Always disconnect the patient from the ventilator system when performing operations that involve risk for the patient, such as replacing the O₂ cell, dismantling etc.

CAUTIONS:

- Never leave the patient unattended when connected to the ventilator system.
- Before use, make sure the system version displayed under *SYSTEM STATUS/General* corresponds to the system version described in the User's Manual.
- Maquet has no responsibility for the safe operation of the ventilator system if the requirements specified in Intended use on page 6 are not followed.
- When lifting or moving the ventilator system or parts of the system, follow established ergonomic guidelines, ask for assistance, and take appropriate safety precautions. The weight is specified on the ventilator system.
- The air inlet filter must be in place when the system is running.

- The expiratory channel and expired gas from the exhaust port may be contaminated.
- If a scavenging system (i.e. gas evacuation) is connected to the ventilator system, it must conform to ISO 80601-2-13 guidelines for subatmospheric pressure and induced flow.
- During operation any water traps must be checked regularly and if necessary emptied.
- All technical documentation is available for use by Maquet authorized personnel.
- When using the MCare Remote Services function, instal the network cable so that there is no risk of anyone tripping over it.
- The ventilator system must not be used with any anaesthetic agent.

Important:

- Portable and mobile radio frequency (RF) communications equipment can affect medical electrical equipment.
- The ventilator system must be installed and put into service according to the EMC declaration.
- Securely attach all cables, etc, to minimize the risk of unintentional disconnection.
- While the ventilator system is in use, the wheels of the mobile cart must be locked and the mobile cart must be in a horizontal position.

- When the ventilator system is connected to a patient:
 - Do not lift or disconnect the expiratory cassette.
 - Continuously monitor the settings and measurements displayed on the screen.
- Always use a heat and moisture exchanger (HME) or an active humidifier to prevent dehydration of lung tissue.
- If a heated patient circuit is not used in the system, a water trap must be used on the expiratory tube to avoid condensation in the system when an active humidifier is used. During operation the water traps must be checked regularly and if necessary emptied.
- Check that the cooling fan intakes are not covered. Do not place the ventilator system on soft surfaces.
- The air inlet filters must be checked regularly and replaced if necessary.
- Use an inspiratory filter when ventilating a highly infectious patient.
- All excess fluids must be disposed of according to hospital routines.
- The emergency air intake must not be blocked.
- Do not disconnect the expiratory cassette while the ventilator system is in operation; if necessary, disconnect the cassette while in *STANDBY*.

Notes:

- Do not simultaneously touch the patient and any accessible connector contacts.
- Do not solely rely on the use of an external monitor to determine the status of the patient and the ventilator system.
- Make sure that the ventilator system is firmly mounted on the mobile cart.
- Make sure that cables and patient circuit is not obstructed or squeezed due to improper mounting.
- Extra care should be taken when handling tubes, connectors and other components of the patient circuit. The use of a support arm to relieve the patient from the weight of the tubing system is recommended.
- Contact a Maquet representative regarding decommissioning of the equipment.
- Turn off the active humidifier during nebulization.
- Expiratory filter connection is mandatory during nebulization.
- A water trap is recommended if a single heated patient circuit is used.
- Thermoshell, expiratory cassette must be used when using heated expiratory tubing or Expiratory heater Servo Duo Guard.

1.2.2 Power supply**WARNINGS!**

- The power cord must be connected only to an AC mains power outlet with protective earth to avoid the risk of electric shock.
- The power supply cord must be plugged directly into the mains power outlet without the use of any multiple socket outlets. If a multiple socket outlet is used together with other products, total leakage current might be exceeded in the event of a fault in the protective earth.

CAUTIONS:

- Do NOT use antistatic or electrically conductive tubing with this system.
- Avoid contact with external electrical connector pins.

Important: In case of total loss of power during ventilation, an alarm will sound for 2 minutes. When power is restored, the ventilator system will start in the same state and with the same settings as before the power loss.

Note: When the system is connected to an external power supply, all connected battery modules are being recharged. This does not affect ventilation.

Battery

WARNINGS!

- Do not use sharp tools when extracting the batteries.
- To guarantee reliable battery backup, make sure a battery is in place in slot 2 at all times during ventilation.
- Dispose of batteries according to local regulations and not with ordinary waste.

CAUTION:

The battery modules must be charged before first use.

Do not expose the batteries to water, fire or excessive heat.

Do not crush, disassemble, puncture or short circuit the connector terminals.

One battery can be added to an available slot during operation.

Hold onto the battery strap when inserting a battery in the ventilator system.

Important:

- If a battery status message is displayed on the screen, always go to *SYSTEM STATUS/Batteries* for detailed information.
- Check battery in *SYSTEM STATUS/Batteries* window to ensure safe battery operation. Always charge the battery before use.
- Always replace batteries when the ventilator system provides notification of imminent expiration or of diminished operating capacity.
- When not in use, the ventilator system should always be connected to the mains power to ensure fully charged batteries.

Refer to section Battery status on page 23.

1.2.3 Fire hazard

WARNINGS!

- Keep all sources of ignition away from the ventilator system and the oxygen hoses.
- Do not use a ventilator system with worn or frayed gas supply hoses or hoses that have been contaminated by combustible materials such as grease or oil.
- Oxygen-enriched gas is extremely flammable: if a burning odor is detected, disconnect the oxygen supply and mains power and remove the batteries.
- Make sure that both the mains power outlet and the power supply connector are accessible.

1.2.4 Gases

WARNING! The ventilator system must not be used with helium or any gas mixture containing helium.

Refer to section Ventilator system on page 134.

1.2.5 Auxiliary equipment

CAUTION:

Measurements of numerical values that have been processed by auxiliary equipment:

- may be inaccurate if equipment not authorized by Maquet is used
- should be disregarded if they conflict with information on the ventilator screen
- must not be used as a substitute for therapeutic or diagnostic decisions.

Accessories, supplies, and auxiliary equipment used with the ventilator system must be recommended by Maquet.

1.3 Version and configurations

This manual applies to version 2.1 of the SERVO-air ventilator system.

1.3.1 Configurations

The ventilator system can be used in both invasive and non invasive ventilation.

The configurations includes adult and pediatric.

Refer to section System on page 132.

1.3.2 Available modes and functions

Modes/Functions	Patient category	
	Pediatric	Adult
PC	X	X
PRVC	O	O
VC	X	X
Bi-Vent/APRV	O	O
PS/CPAP	X	X
VS	O	O
Automode	O	O
SIMV		
• (PC) + PS	X	X
• (PRVC) + PS	O	O
• (VC) + PS	X	X
NIV PC	O	O
NIV PS	O	O
Nebulizer	X	X
Alarm output connection	O	O

X = standard

– = not applicable

O = option

2 System Overview

Table of contents

2.1	Ventilator		16
2.2	Patient unit		18
2.3	Batteries		22
2.4	Patient circuit		24
2.5	User interface		29
2.6	Transport		36

2.1 Ventilator

The ventilator consists of a user interface and a patient unit.

Air is supplied from ambient air by an internal turbine and O₂ may be supplied by a medical pipeline system or by gas cylinder.

2.1.1 Mounting on mobile cart

- Lock the wheels.
- Release the locking clamp on the mobile cart.
- Stand directly in front of the mobile cart when mounting the ventilator system.
- Tilt the ventilator system to fit the two front clamps in position on the mobile cart.
- Press down the rear end of the ventilator to fit the rear clamp in position.
- Lock the ventilator system to the mobile cart with the locking clamp.
- Ensure that the patient unit is firmly fixed to the mobile cart via the clamps and locking clamp.

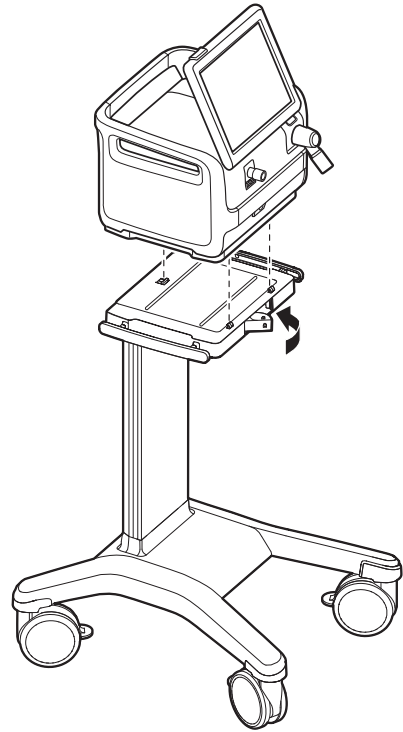

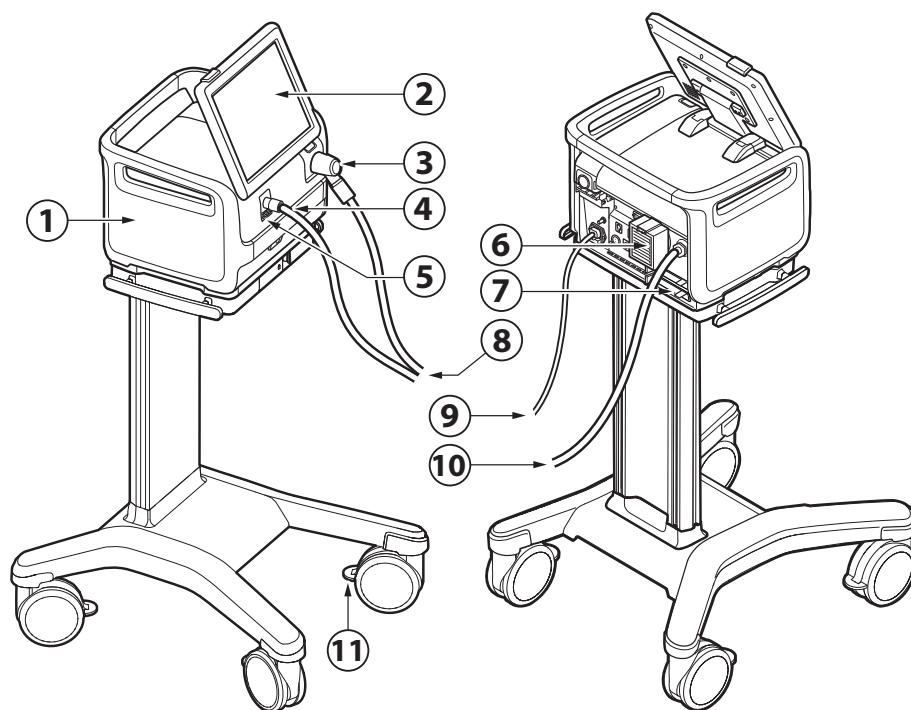

1. Patient unit
2. User interface
3. Expiratory inlet
4. Inspiratory outlet
5. Emergency air intake
6. Air inlet
7. Battery compartment
8. Patient circuit
9. AC mains power
10. O2 supply
11. Wheel lock

Note: Lock the wheels whenever the ventilator system is standing still.

2.2 Patient unit

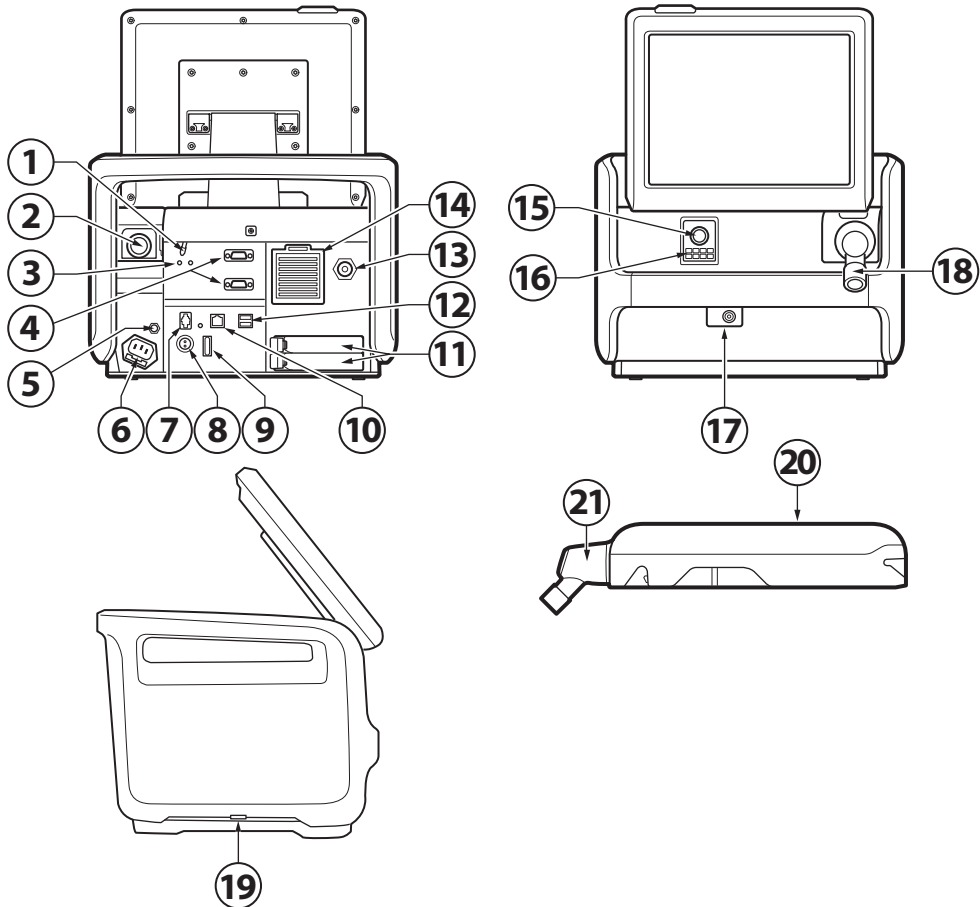















1. On/Off switch
The switch must be pulled downwards before it can be switched.
2. Expiratory outlet
3. Power indicators
4. RS-232 connectors
5. Equipotentiality terminal.
6. AC mains power source connector with fuse
7. Alarm output connection
8. External +12V DC inlet
9. Fuse for external DC power
10. Ethernet connection

11. Battery compartments
12. USB ports
13. Gas inlet for O₂
14. Gas inlet for air including air inlet filter
15. Inspiratory outlet
16. Emergency air intake
17. Nebulizer connector
18. Expiratory inlet
19. Cooling fan with filter (on both sides)
20. Expiratory cassette
21. Expiratory inlet with moisture trap

Important: No other external devices than a USB memory stick may be connected to the USB ports. Only one memory stick can be used at the same time.

2.2.1 Symbols on patient unit

Symbol	Description
	CE label—indicates compliance with the requirements of the Medical Device Directive 93/42/EEC
	CSA label—Indicates compliance with Canadian and US standards
	UDI Label - Unique Device Identification. Refer to section UDI label on page 156.
	In USA, Federal law restricts this device to sale by or on the order of a physician.
	Type B—indicates classification according to IEC 60601-1
	Type BF applied part — indicates classification according to IEC 60601-1
	Potential equalization terminal Note: The potential equalization terminal is designed for the connection of a potential equalization conductor according to DIN 42 801 and IEC 60601-1. The function of the potential equalization terminal is to equalize potentials between the ventilator system and other medical devices that can be touched simultaneously. The potential equalization terminal must not be used for a protective earth connection.
	Nebulizer connector
	RS-232/Serial port - connector for data communication
	Ingress protection, IP21
	Fuse (specification)
	External 12V DC input
	Battery
	Expiratory gas flow from the patient
	Inspiratory gas flow to patient

Symbol	Description
	Mains power On/Off
	Mains connected, batteries charging
	Gas exhaust port—exhaust gas flow from ventilator system
	Network connection
	USB connection
	Alarm output connection
	Special waste Note: This product contains electronic and electrical components. Discard disposable, replaced and left-over parts in accordance with appropriate industrial and environmental standards.
	Caution
	Consult instructions for use
	Consult accompanying documentation
	Locked
	Unlocked
	Serial number
	Order number
	Weight of patient unit with user interface and ventilator including its safe working load.
	Use of ON/OFF switch The switch must be pulled downwards before it can be switched.
	Manufacturer The symbol is accompanied by manufacturer address and manufacturing date.

Symbol	Description
	MR Unsafe - keep away from magnetic resonance imaging (MRI) equipment.

2.2.2 Gas flow through the patient unit

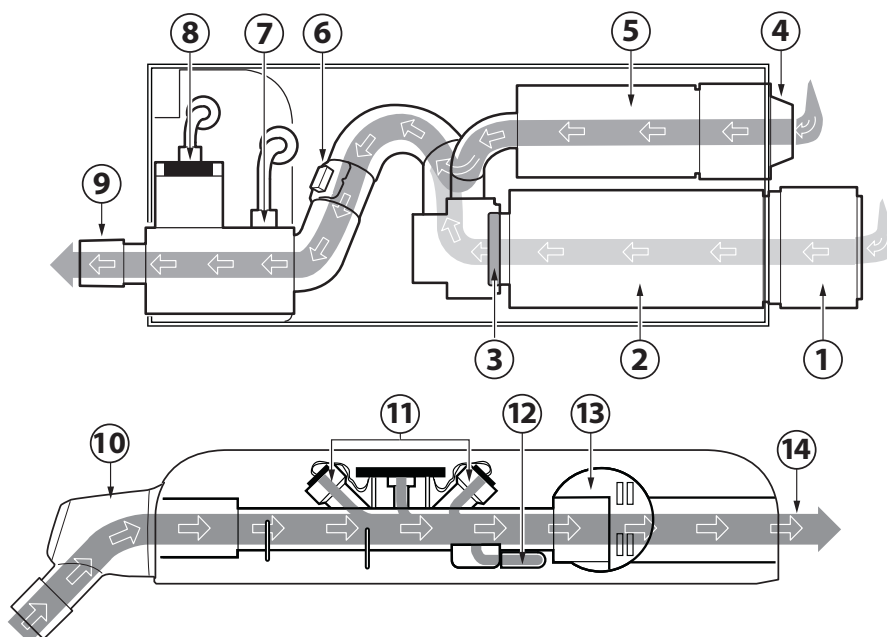

1. Air inlet with air inlet filter.
2. Turbine module for ambient air.
3. The check valve prevents the gas to flow backwards.
4. Gas inlet for O₂.
5. The gas module for O₂ regulates the O₂ gas flow.
6. The flow meter measures the gas flow.
7. The pressure of the gas delivered to the patient is measured by the inspiratory pressure transducer. The transducer is protected by a bacterial filter.
8. The O₂ cell measures the oxygen concentration. The O₂ cell is protected by a bacterial/viral filter.
9. The inspiratory channel delivers gas to the patient circuit inspiratory tubing and contains a safety valve.
10. The expiratory inlet in the expiratory cassette contains a moisture trap.
11. The ultrasonic transducers in the expiratory cassette measure the outgoing gas flow.
12. The expiratory pressure transducer in the expiratory cassette measures the pressure in the patient circuit. The transducer is protected by a bacterial filter.
13. The expiratory valve in the expiratory cassette regulates the pressure in the patient circuit.
14. Exhaust port.

Note: The expiratory cassette can be exchanged between different ventilator systems. Always perform a pre-use check after exchanging an expiratory cassette.

2.3 Batteries

2.3.1 Charging battery modules

Important: The battery modules are delivered in shipping-mode and must be charged before use.

To charge the battery modules, insert the battery modules in the ventilator system. The ventilator must be connected to mains. The battery modules are charged automatically.

The batteries can also be charged with the External battery charger, SERVO-air.

2.3.2 Handling battery modules

The battery compartment is divided into two slots, 1 and 2.

The ventilator system uses the battery in slot 1 first. Make sure that the battery in slot 2 is in place as a backup at all times during ventilation.

Refer to section Battery on page 12.

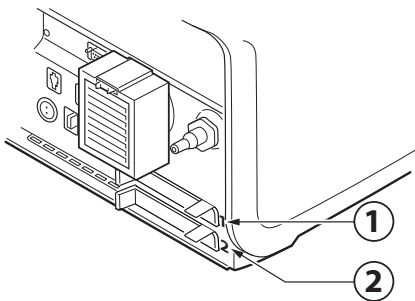

The battery module in slot 1 may be exchanged during ventilation.

To remove a battery module:

- Press the release button to the left and pull the battery strap.

- Remove the battery from the ventilator system.

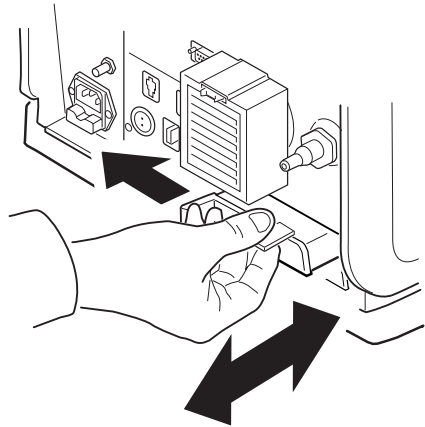

To insert a battery module:

- Hold onto the battery strap when inserting a battery in the ventilator system. When inserting a battery module in slot 1, check that the battery strap for the battery in slot 2 is not folded into the battery compartment.
- Ensure that the battery is fully inserted so that the release button returns to a completely closed position.

2.3.3 Battery status

Important:

- If *Replace battery* is displayed, the battery is unreliable, regardless of the operating time displayed under *Batteries*. In this situation, replace the battery even when the *STATUS* window indicates that significant operating time remains.
- At least one battery module must always be installed.

Detailed information about batteries is accessed via *SYSTEM STATUS/Batteries*. There is also an indication in the status bar showing the power supply currently being used by the ventilator system.

If the ventilator system is running on battery power, the active battery in the battery symbol turns yellow and the mains power symbol disappears. The estimated remaining battery time in minutes is always displayed, regardless of the power supply in use.

The battery symbol also functions as a shortcut to the window otherwise accessed via *SYSTEM STATUS/Batteries*.

The following information is displayed under *Batteries* in *SYSTEM STATUS* for each connected battery module:

- *BATTERY CAPACITY* – usable backup time in minutes

An estimated backup time is shown in Standby. This estimate may differ from the actual usable backup time during running. Usable backup time depends on set mode and selected ventilation settings.

Note: The presented usable backup time is the sum of the estimated operation time displayed for each battery module minus 20 minutes.

- Slot number
- Serial number
- Remaining operation time in minutes for each battery
- Notification – may be displayed close to the remaining operation time in minutes.
- Remaining battery life

2.4 Patient circuit

Notes:

- Turn off the active humidifier during nebulization.
- Expiratory filter connection is mandatory during nebulization.
- A water trap is recommended if a single heated patient circuit is used.
- Thermoshell, expiratory cassette must be used when using heated expiratory tubing or Expiratory heater Servo Duo Guard.
- To ensure that the inspiratory gas temperature is below 43°C the patient circuit inspiratory tube must be at least 1.2 m to let the gas cool down.

Refer to *System Flow Chart, SERVO-air* for information regarding patient circuit configurations to be used with the ventilator system.

15 - 22 mm Ø patient circuit, reusable

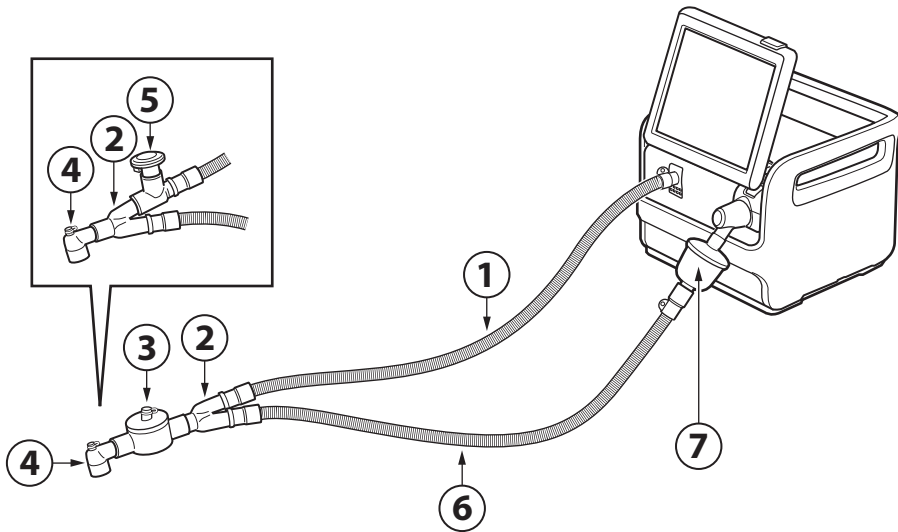

- | | |
|---|----------------------------|
| 1. Inspiratory patient tube | 5. Aerogen Pro |
| 2. Y piece | 6. Expiratory patient tube |
| 3. Heat and moisture exchanger (HME) | 7. Expiratory filter |
| 4. Angled adapter for endotracheal tube | |

22 mm Ø patient circuit, dual heat disposable

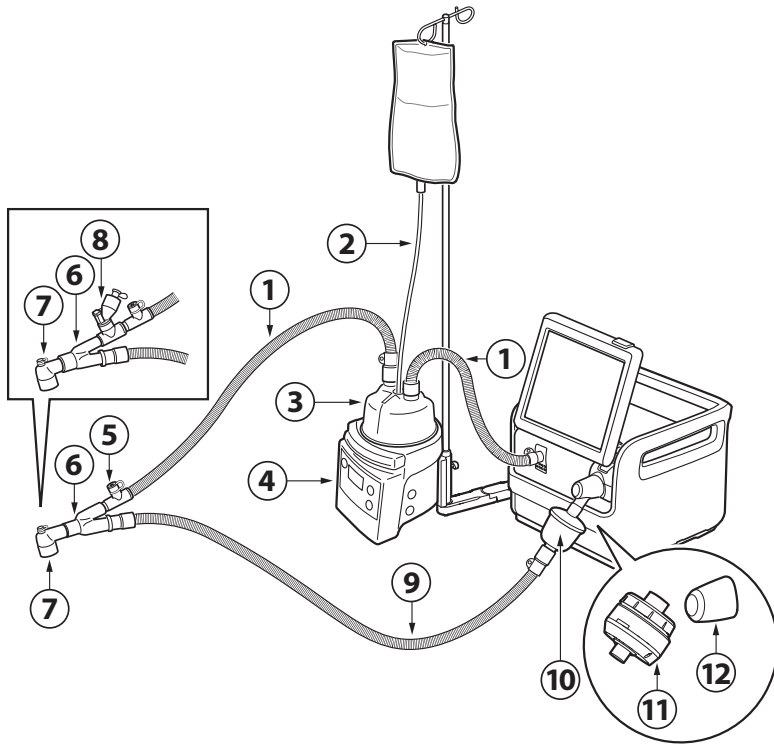

- | | |
|-------------------------------|---|
| 1. Inspiratory patient tube | 7. Angled adapter for endotracheal tube |
| 2. Water autofill | 8. Aerogen Solo |
| 3. Humidification chamber | 9. Expiratory patient tube |
| 4. Active humidifier | 10. Expiratory filter |
| 5. Cuff with temperature port | 11. Expiratory heater Servo Duo Guard |
| 6. Y piece | 12. Thermoshell, expiratory cassette |

10 mm Ø patient circuit, single heat reusable

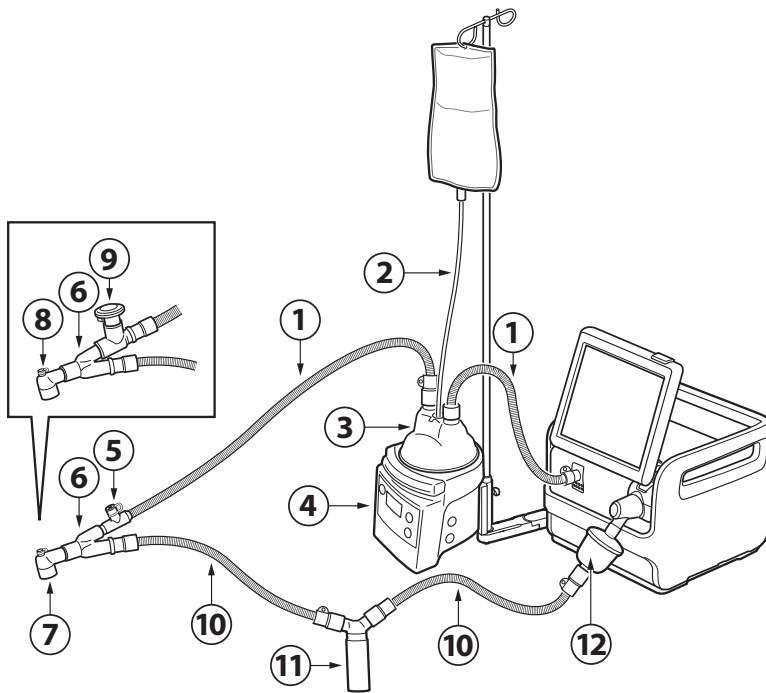

- | | |
|-------------------------------|---|
| 1. Inspiratory patient tube | 7. Angled adapter for endotracheal tube |
| 2. Water autofill | 8. Pressure line connection port |
| 3. Humidification chamber | 9. Aerogen Pro |
| 4. Active humidifier | 10. Expiratory patient tube |
| 5. Cuff with temperature port | 11. Water trap |
| 6. Y piece | 12. Expiratory filter |

10 mm Ø patient circuit, dual heat disposable

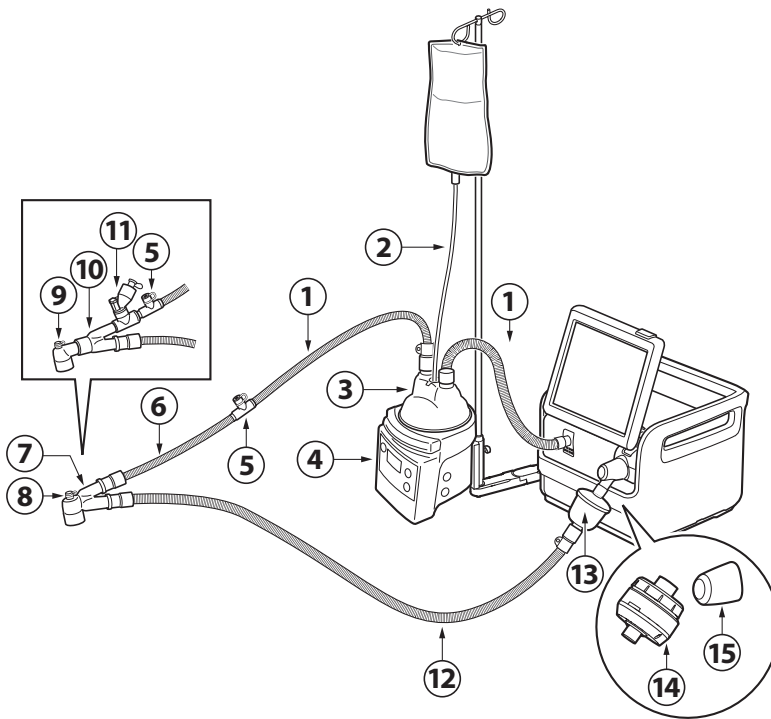

- | | |
|-------------------------------------|---|
| 1. Inspiratory patient tube | 9. Angled adapter for endotracheal tube |
| 2. Water autofill | 10. Y piece |
| 3. Humidification chamber | 11. Aerogen Solo |
| 4. Active humidifier | 12. Expiratory patient tube |
| 5. Cuff with temperature port | 13. Expiratory filter |
| 6. Extension tube for incubator use | 14. Expiratory heater Servo Duo Guard |
| 7. Angled Y piece | 15. Thermoshell, expiratory cassette |
| 8. Pressure line connection port | |

2.5 User interface

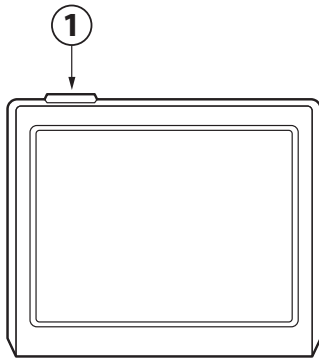

1. Alarm indicator

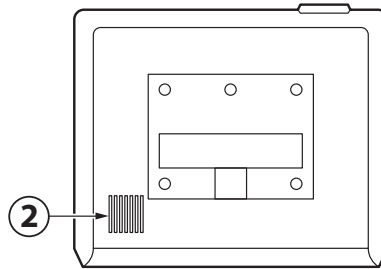

2. Loudspeaker

2.5.1 User interface adjustment

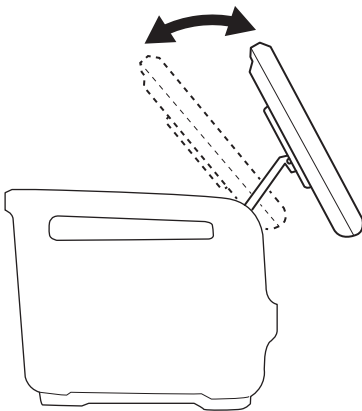

The user interface can be adjusted into different positions.

2.5.2 Interactive areas

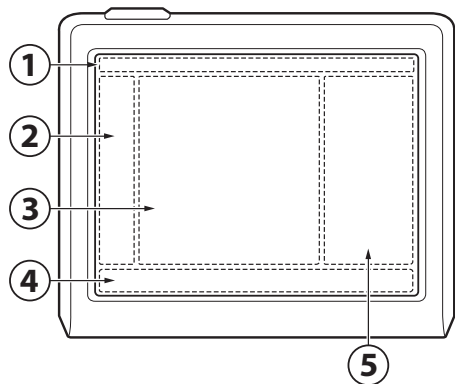

The user interface is completely touch based and is divided into the following areas:

1. Status bar
2. Quick menu/extended menu
3. Display area
4. Direct access bar/media bar
5. Numerical values

Important:

- Do not use sharp tools on the screen.
- Fluid on the screen can disturb touch functionality.

2.5.3 Navigating

To navigate the user interface, adjust settings and get support:

- Tap (the touchpad changes color when the navigating is registered).
- Tap and hold
- Scroll vertically or horizontally
- Drag and drop

2.5.4 User support

The user is supported by the following:

- Alarm management
- Safety scales
- Dynamic images
- Information texts
- Pre-use check instructions
- Shortcuts
- Prompts

Note:

The following colors are used for settings:

- Red — not recommended
- Yellow — use with caution
- Green — normal

Alarm management

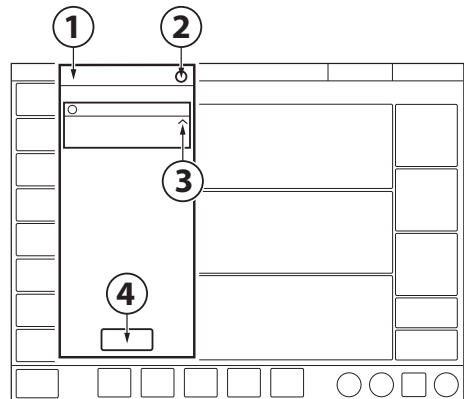

1. Alarm list
2. Number of active alarms
3. Alarm management checklist
4. Alarm history

Refer to chapter Alarm handling on page 109.

Safety scales

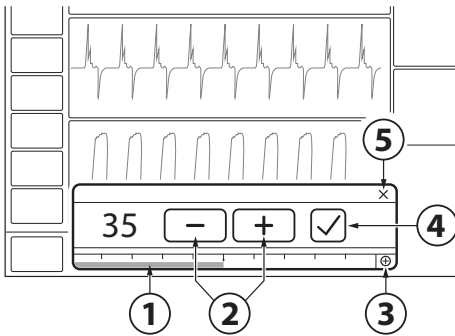

1. Slide bar
2. Increase/decrease setting
3. Full settings range
4. Accept
5. Cancel

Refer to section Safety scales on page 41.

Dynamic images

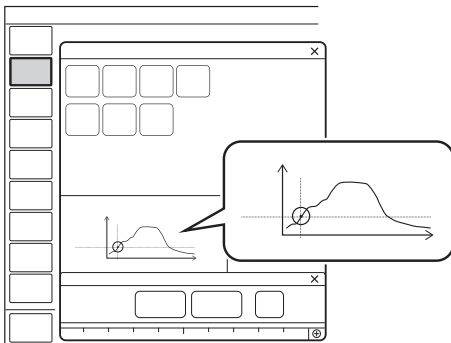

The dynamic image illustrates the effects of the changes made to selected ventilation settings.

Information texts

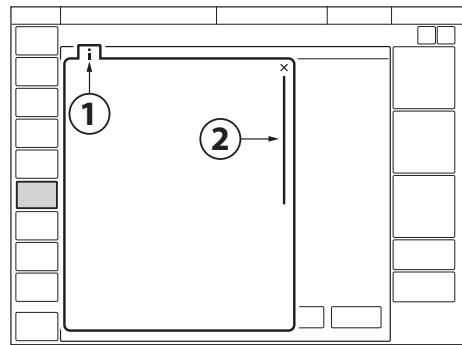

1. Information text is available.
2. Indication that more information is available by scrolling vertically in the middle of the information window.

Shortcuts

Some frequently used functions can be accessed via a shortcut. There are shortcuts to the following windows:

- Alarm limits
- Patient data
- Battery status
- Leakage compensation deactivation
- Circuit compensation deactivation
- Nebulization

Refer to section Symbols on user interface on page 32.

Prompts

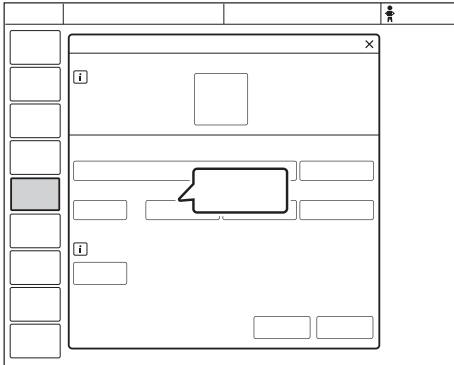

Prompts indicate that input is required.

2.5.5 Symbols on user interface

Symbol	Description
	Extended menu show/extended menu hide
	Start ventilation
	Stop ventilation/Standby
	Do not push the user interface as the ventilator system may tip over.
	Alarm limits/Alarm limits shortcut
	Audio pause
	Audio paused
	Audio off
	Audio pause - all alarms, active and inactive are pre-silenced.
	Alarm on
	Alarm off
	Check alarms
	Alarm sound level
	Alarm history
	Message
	Number of messages
	Adult/patient data shortcut
	Pediatric/patient data shortcut
	AC mains power
	Missing battery
	Unknown battery (not a Maquet battery)















Symbol	Description
	Charging battery
1 xx min 2	Total battery capacity, active battery and battery status shortcut
	External 12V DC power
	Backup on
	Backup off
	Circuit compensation on
	Circuit compensation off/Circuit compensation deactivation shortcut
	Invasive ventilation adult
	Invasive ventilation pediatric
	Non invasive ventilation adult
	Non invasive ventilation pediatric
	Two overlay loops
	Reference loop
	Loop grid on
	Loop grid off
	Compensation
	Configuration
	Maneuvers
	Media
	Modes
	Patient data
	System status
	Trends & logs
	Views





Symbol	Description
	Screen layout
	Disconnect
	Service & Settings
	Biomed
	Service
	Remote services
	Exit
	Nebulization period/Nebulization shortcut
	Continuous nebulization/Nebulization shortcut
	O ₂ boost locked to 100 %
	Pneumatic trigger, pressure/flow
	Organize
	Panel locked
	Panel unlocked
	Progress
	Full settings range
	Normal settings range
	Recorder
	Recording waveforms 30 seconds
	Recording waveforms in progress
	Camera for taking screenshots
	Value not within range
	Uncertain value
	Test failed (red)
	Test not performed (yellow)

Symbol	Description
	Test passed (green)
	Accept
	Decrease
	Increase
	Information text
	Cancel (red) Close (green)
	Switch between main/backup modes
	Additional values & settings hide/Additional values & settings show
	Additional information hide/Additional information show

2.5.6 Symbols on accessories and packaging

Symbol	Description
	CE label—indicates compliance with the requirements of the Medical Device Directive 93/42/EEC
0123	
	Order number
	Number to identify the production batch
QTY	Quantity
	Outer diameter in mm
	Inner diameter in mm
	Indicates the inner diameter of the endotracheal tube
Fr/cm	Circumference/length
	Use by date
	Do not re-use. Single use only.
	Do not use if packaging is damaged
	Consult accompanying documentation
	Keep away from sunlight
	Manufacturer The symbol is accompanied by manufacturer address and manufacturing date.
	Manufacturing date
Rx ONLY	In USA, Federal law restricts this device to sale by or on the order of a physician.
	Recyclable material. Recycling must be performed in accordance with appropriate industrial and environmental standards.

Symbol	Description
	Special waste to be disposed of in accordance with appropriate industrial and environmental standards
Pb	
	Gas cylinder
	Defibrillation proof Type CF applied part - indicates classification according to IEC 60601-1
	Type BF applied part — indicates classification according to IEC 60601-1
	Type B—indicates classification according to IEC 60601-1
	Humidity limitation
	Temperature limitation
	Fragile — handle with care
	Keep away from water
	This way up — indicates correct upright position of the transport package
	Atmospheric pressure limitation
	Do not expose to heat or fire.
	Do not expose to mechanical force.
	Do not dismantle, open or shred.

Symbol	Description
	The support arm must be folded during transport.
	Locked
	Unlocked
	Consult instructions for use

2.6 Transport

2.6.1 Before intrahospital transport

Before transporting the ventilator system with or without a patient connected, follow facility guidelines and:

- Be sure that the patient unit is securely attached and locked.
- Be sure that all accessories such as battery modules, gas cylinder, and humidifier are securely attached and locked.
- Be sure that the gas cylinders are connected and have sufficient gas.
- Be sure that the straps are firmly wrapped across the center of the gas cylinders so that the cylinders do not move during transport.
- Be sure that the battery in slot 2 is fully charged.
- Inspect the resuscitator.
- Inspect the mobile cart for damage.
- Be sure that the support arm is folded before transport.

2.6.2 During intrahospital transport

While transporting the ventilator system with or without a patient connected, follow facility guidelines and:

- Use the handles on the patient unit.
- Transport the bed and the ventilator system slowly, and watch the patient connection carefully to see that no pulling or other movement occurs.
- If triggering problems occur during intrahospital transport because of extreme vibrations, Pressure Control mode is recommended or to set the trigger so that it is less sensitive.
- Be careful not to tip the mobile cart when crossing an obstacle like a threshold.
- On arrival, connect the ventilator system to mains power and lock the brakes.

CAUTION: Do not load the ventilator equipment asymmetrically on the ventilator system to avoid instability.

3 Operation overview

Table of contents

3.1	Workflow summary		38
3.2	Pre-use check		38
3.3	Patient circuit test		39
3.4	Select patient category		40
3.5	Select ventilation type		40
3.6	Set ventilation mode		41
3.7	Set alarm limits		42
3.8	Enter patient data		43
3.9	Start ventilation		44
3.10	Stop ventilation		44

3.1 Workflow summary

- Turn on the ventilator system, prepare the patient circuit to be used and perform a pre-use check.
- Select patient category.
- Select invasive or non invasive ventilation.
- Set the ventilation mode.
- Check, and if necessary, adjust the alarm limits.
- Enter data for the new patient, including height, weight, and gender (optional).
- Start ventilation and connect the ventilator system to the patient.
- Adjust alarm limits if necessary.

Stop ventilation when desired.

3.2 Pre-use check

The pre-use check contains a number of tests that the ventilator system automatically performs.

Refer to section Pre-use check tests on page 140.

Each test starts automatically when the previous test is completed.

To ensure correct system functionality, optimal performance and patient safety, a pre-use check must be performed.

WARNINGS!

- Always perform a pre-use check before connecting the ventilator system to a patient.
- Do not connect the ventilator system to a patient while a malfunction persists.

Important:

- When the pre-use check is completed, all sources of alarm signals and alarm conditions have been verified and the alarm system operates correctly.
- The volume of the patient circuit used during pre-use check should be the same as during ventilation.
If the patient circuit is changed after the pre-use check is completed, perform a new pre-use check or a patient circuit test.

3.2.1 Start pre-use check

- Connect the ventilator system to a mains power outlet.
- Connect the ventilator system to O₂ gas supply.
- Turn the ventilator system on.
Refer to section Patient unit on page 18.
- Tap *PRE-USE CHECK* in *STANDBY*.
- Tap Yes in the *PRE-USE CHECK* window to start, and follow on-screen instructions.

3.2.2 Complete pre-use check

A symbol and a color marking appear on screen for each pre-use check test, as appropriate: *Passed*, *Failed* and *Not performed*.

- Tap *OK* to confirm or tap *Redo test* to restart a pre-use check test.

The ventilator system returns to *STANDBY* when the pre-use check is completed.

Notes:

- The status of the two latest pre-use checks and patient circuit tests is displayed under *SYSTEM STATUS/General*.
- The status of the latest pre-use check and patient circuit test is also displayed in *STANDBY*.

3.3 Patient circuit test

In *Standby*, the patient circuit test may be performed separately from the pre-use check.

CAUTION: The patient circuit test must be performed with a complete patient circuit, including all accessories (e.g. active humidifier filled with water, filter and nebulizer), that is to be used with the patient.

The patient circuit test measures resistance and compliance in the patient circuit. If the patient circuit is changed and no new patient circuit test is performed, the ventilator will compensate incorrectly based on the measurements of the previous patient circuit. If the correct circuit is not tested, the following risks may arise:

- In volume-based modes, the volume delivered to the patient will be incorrect.
- In pressure-based modes, the volume measured will be incorrect.

Tap *PATIENT CIRCUIT TEST* and follow on-screen instructions.

The result from the patient circuit test is displayed in *PATIENT CIRCUIT TEST* in *STANDBY*. Detailed result are displayed in the *SYSTEM STATUS/General* window.

Important: The patient circuit test does not replace the pre-use check.

3.4 Select patient category

- Tap patient category in *STANDBY*. All available patient categories appear.
- Select the appropriate patient category.
The patient data shortcut in the status bar changes accordingly.

Important: Always check the alarm settings after changing the patient category.

Notes:

- Changing the patient category affects the following settings:
 - default values for alarm limits
 - allowed ranges for alarm limits
 - default values for ventilatory settings
 - allowed ranges for ventilatory settings
 - pressure and flow regulation
 - scaling
- The default values may have been changed by a previous user.

3.4.1 Change patient category

To change the patient category during ventilation:

- Tap the patient data shortcut in the status bar or tap *PATIENT DATA* in the quick menu.
- Select the appropriate patient category.
- Follow on-screen instructions.

3.5 Select ventilation type

- Select invasive or non invasive ventilation in *STANDBY*.

Note: The default values may have been changed by a previous user.

3.6 Set ventilation mode

- Tap *MODES* in *STANDBY* to open the *MODES* window.
- Select mode.

Note: Tap and hold the tile to access more information about the selected mode.

- When a ventilation mode has been selected, all parameters can be set in the mode settings window.
- Tap a parameter to adjust its value.
- Tap *Accept* to confirm, or *Cancel* to cancel the settings.

3.6.1 Settings

Important: If one or several settings in the mode settings window are highlighted in yellow, this indicates that it/they should be considered for adjustment, as the values entered there may have been carried over from the previous mode.

Refer to section Ventilatory settings on page 142.

3.6.2 Safety scales

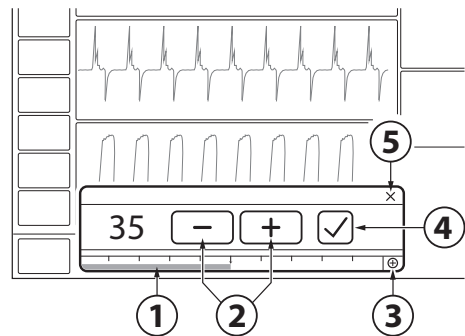

1. Slide the bar to the right or left to increase or decrease the settings. The bar displays the safety scale, that is the range that is safe to use for most patients.
2. Tap to incrementally increase or decrease the setting. Tap and hold to rapidly increase or decrease the setting.
3. Tap on full settings range to extend the safety scale setting range.
4. Confirm the setting by tapping *Accept*.
5. Exit settings without changing by tapping cancel.

3.7 Set alarm limits

- Tap *ALARM LIMITS* in the quick menu.
- The limits are set in the alarm limit bars in the *ALARM LIMITS* window.

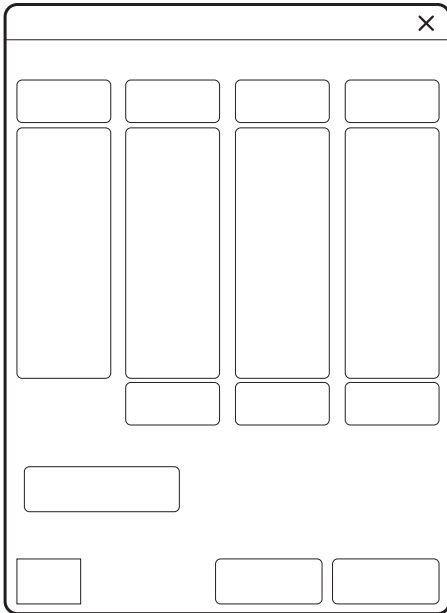

- Tap the upper or lower value in the selected alarm limit bar.
- A scale appears, tap plus or minus or slide the bar to set the value.

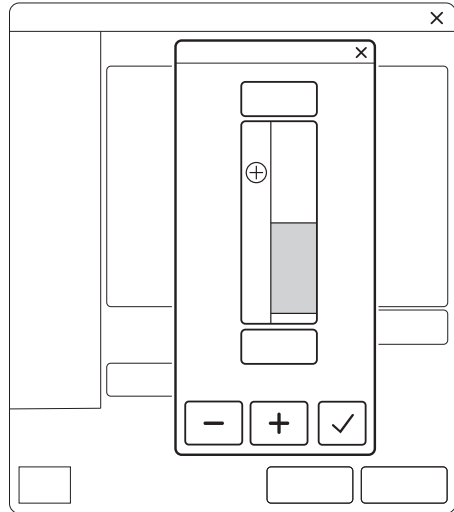

Confirm each setting by tapping *Accept*.

Tap *Autoset all alarms*, if desired, to get alarm limit proposals for the following modes:

- VC
- PC
- PRVC

Important: Before accepting *Autoset all alarms* values, make sure they are appropriate for the patient. If not, enter settings manually.

To activate the new alarm limits tap *Accept*.

Note: *Autoset all alarms* is not available in supported or *NIV* modes or in *STANDBY* because the ventilator system requires patient values in order to propose alarm limits.

3.7.1 Set alarm sound level

The ambient sound needs to be taken into consideration when setting the alarm sound level.

- Tap *ALARM LIMITS* in the quick menu.
- Tap alarm sound level.

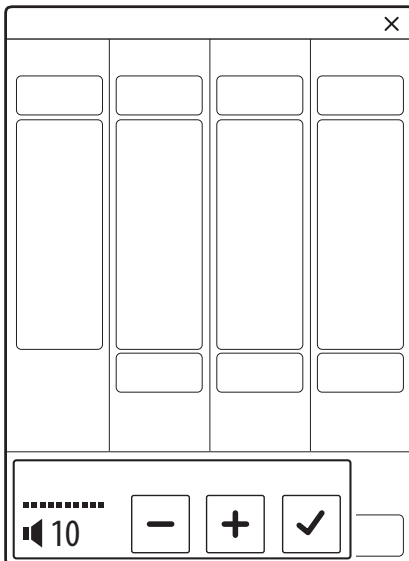

- Tap the sound level bar to set appropriate alarm sound level.
- Tap *Accept*.

3.8 Enter patient data

- Tap the patient data shortcut in the status bar or tap *PATIENT DATA* in the quick menu.
- Tap in the selected input field to open a keyboard or keypad.
- Tap *Accept* to confirm new data.
- Enter/edit the following data:
 - *Patient category*
 - *Name*
 - *Date of birth / ID*
 - *Gender*
 - *Height*
 - *Weight*

Note: If gender, height and weight have been entered, predicted body weight will be automatically displayed.

Refer to section Predicted body weight (PBW) on page 91.

- Tap *Done* when entry is complete.

3.9 Start ventilation

Tap *START VENTILATION* in *STANDBY* or *START* in the quick menu to start ventilation.

WARNING! Ventilation must be started manually when a patient is connected to the ventilator system.

3.10 Stop ventilation

To disconnect and stop ventilation:

- Physically disconnect the patient from the ventilator system.
- Tap *STANDBY* in the quick menu.
- Tap and hold *STOP VENTILATION* to stop ventilation.

4 Displaying and saving data

Table of contents

4.1	Views		46
4.2	Displaying waveforms		49
4.3	Displaying numerical values		50
4.4	Trends and logs		50
4.5	Saving and exporting data		51
4.6	Ventilator configuration		53
4.7	System status		54

4.1 Views

The ventilator system offers different views to suit different needs. They are accessed via the quick menu during ventilation.

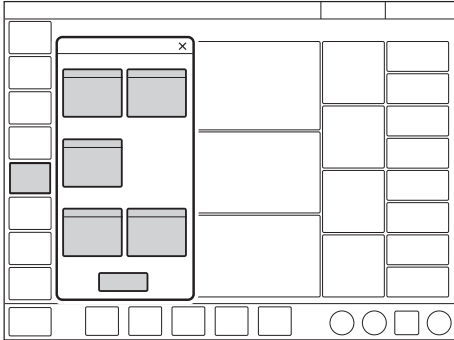

4.1.1 Basic view

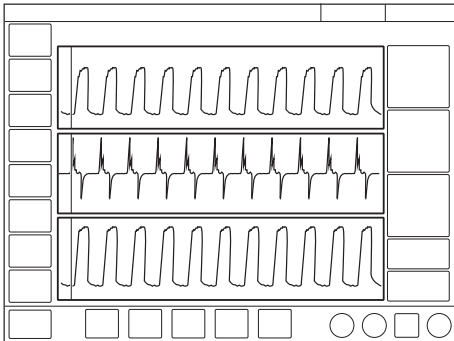

The view consists of:

- two or three waveforms – pressure and flow waveforms are always present, together with the volume waveform, if desired
- a single column of numerical values

Note: All non invasive ventilation modes start in the *BASIC* view.

It is possible to adjust the layout by tapping either *SCREEN LAYOUT* in the extended menu or *VIEWS/Screen layout* in the quick menu.

This makes it possible to show or hide the volume waveform.

Refer to section *Adapting the waveform display* on page 49.

It is also possible to adjust the scaling, sweep speed, appearance of the waveforms and user interface brightness in the *SCREEN LAYOUT* window.

4.1.2 Advanced view

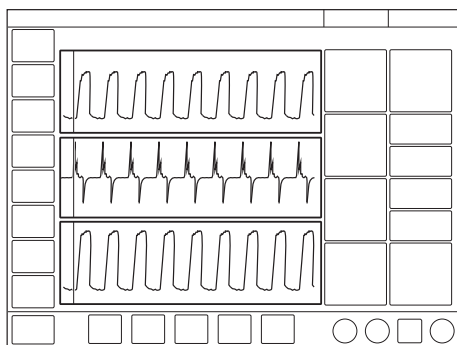

The view consists of:

- two to three waveforms – pressure and flow waveforms are always present, together with the volume waveform, if desired
- two columns of numerical values

Note: All invasive ventilation modes start in the *ADVANCED* view.

It is possible to adjust the layout by tapping either *SCREEN LAYOUT* in the extended menu or *IEWS/Screen layout* in the quick menu.

Refer to section Adapting the waveform display on page 49.

4.1.3 Loops view

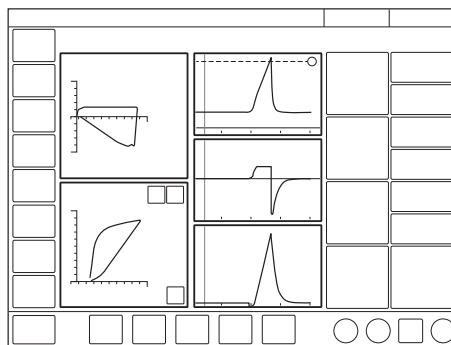

This view provides a graphical representation of the relationship between pressure-flow, pressure-volume and volume-flow.

The view consists of:

- up to three loops – pressure-flow, pressure-volume and volume-flow
- two to three waveforms – pressure and flow waveforms are always present, together with the volume waveform, if desired
- two columns of numerical values

Note: The *LOOPS* view is not available in non invasive modes.

It is possible to adjust the layout by tapping either *SCREEN LAYOUT* in the extended menu or *IEWS/Screen layout* in the quick menu.

It is also possible to adjust the scaling, sweep speed, appearance of the waveforms and user interface brightness in the *SCREEN LAYOUT* window.

Refer to section Adapting the waveform display on page 49.

In addition, all loops can be shown or hidden. The maximum number of loops displayed is three, in which case no more than three waveforms may be displayed. The loops may also be displayed with or without a loop grid by tapping *Loop grid*.

To store a reference loop or see two overlaid loops simultaneously:

1. Tap the reference loop symbol. A reference loop will then be displayed together with a time stamp.
2. Tap the two overlay loops symbol to display the two previous loops.

4.1.4 Family view

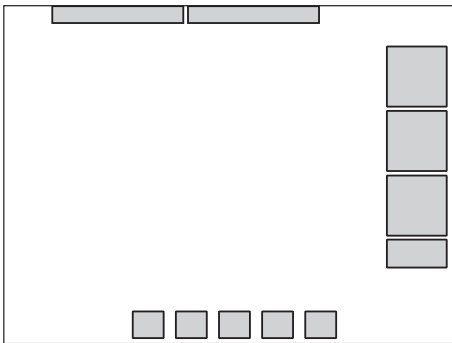

The view has a neutral background image and may be used during family visits to hide the standard user interface.

Displayed information is minimized to:

- one column of numerical values
- the direct access bar
- alarms and messages in the status bar
- a dynamic representation (moving bubbles) showing that ventilation is in progress.

The screen layout cannot be adjusted.

Tap anywhere on the screen for rapid access to the most recently used view.

4.1.5 Distance view

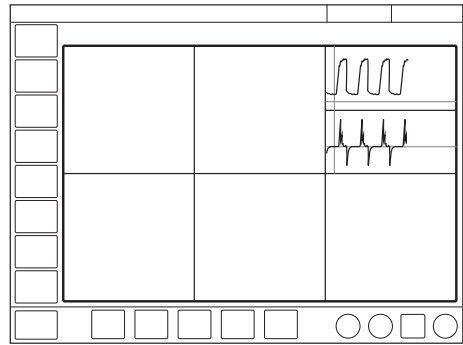

The view is designed for optimal readability from a distance. Information displayed includes numerical values and waveforms.

There are six large tiles displaying:

- five enlarged numerical values
- the pressure and flow waveforms

The screen layout cannot be adjusted.

4.2 Displaying waveforms

The ventilator system can display a minimum of two waveforms and a maximum of three, depending on the view selected.

Pressure and flow waveforms are always mandatory except in the *FAMILY* view.

The waveforms displayed on the user interface are:

- pressure – (yellow)
- flow – (green)
- volume – depending on view selected and layout adjustments (blue)

4.2.1 Adapting the waveform display

It is possible to adapt the waveform display via the scaling function.

- Tap and hold a displayed waveform.
- In the window that opens, adjust the scaling function manually or use *Auto* to scale automatically.
- To close the window, tap anywhere on the screen other than the opened window.

Alternatively:

- Adjust the layout by tapping either *SCREEN LAYOUT* in the extended menu or *VIEWS/Screen layout* in the quick menu.
- Tap the tile shown in the figure directly to the left of each waveform name.

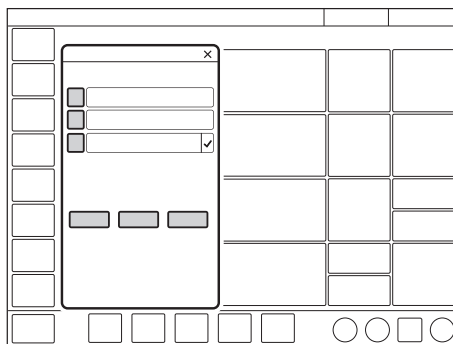

It is also possible to show or hide non-mandatory waveforms in the *SCREEN LAYOUT* window.

The sweep speed can be adjusted by tapping *Sweep speed* and selecting either of three speeds.

In addition, there is a choice under *Appearance* between filled and unfilled waveforms.

4.3 Displaying numerical values

During ventilation, numerical values (measured or calculated) are displayed on the right side of the screen.

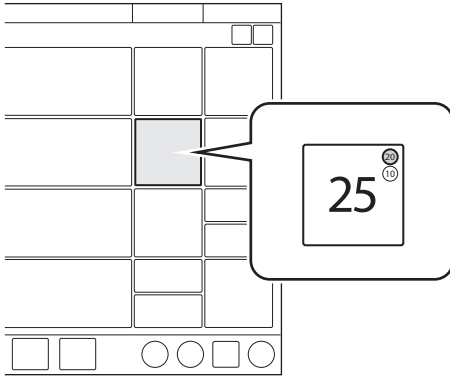

- Alarm limits (if applicable) are displayed in small digits for each numerical value.
- Values that are off the scale are replaced by three asterisks.
- Values that are uncertain are indicated by a single asterisk.

Depending on the view, either one or two columns of numerical values are displayed.

To access additional values, tap the arrow at the right edge of the screen to display all numerical values.

4.4 Trends and logs

4.4.1 Trends

Trend values are stored every 60 seconds and retained for a maximum of 72 hours. Stored events and system changes are also displayed here.

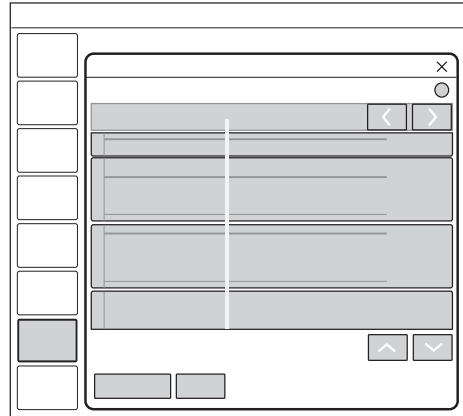

To view trends:

- In the extended menu, tap *TRENDS & LOGS / TRENDS*.
- To adjust the time resolution, tap the number of hours displayed.
- The time valid for the cursor position is displayed. If events have been stored, their number is displayed in the circle shown in the figure and an explanation appears to the left of this circle.
- If a recording is saved at a time corresponding to the cursor position, a recorder is displayed. To view the recording, tap this recorder.
- Tap *Organize trends* to place the trends in the desired order by dragging and dropping the different trended values presented.

Refer to section Trends on page 147.

4.4.2 Logs

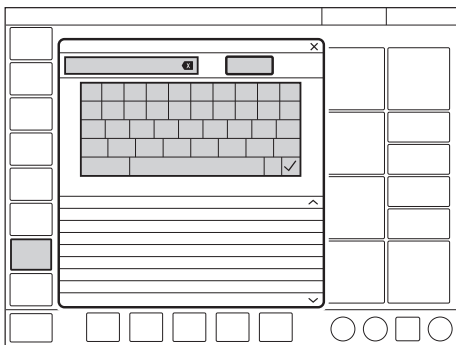

To view the event log:

- In the extended menu, tap *TRENDS & LOGS /LOGS*.
- Scroll among all the events listed.
- The *LOGS* window offers a search function. Tap the text field to open the keyboard and enter a search word. To display only log items that contain the search word entered, tap *Filter*. Tap again to deactivate the filter.
- Use the backspace arrow to delete the search word.

Each event includes the event time and date. The event log is cleared when a new patient is admitted.

Refer to section Event log on page 148.

4.5 Saving and exporting data

Data can be saved in a number of ways:

- as screenshots
- as recordings
- as files for export including event log, trends and both the above.

The screenshots and recordings are stored under *MEDIA*.

Data can later be exported to a USB memory stick.

4.5.1 Saving screenshots

To save a screenshot, tap the camera in the status bar.

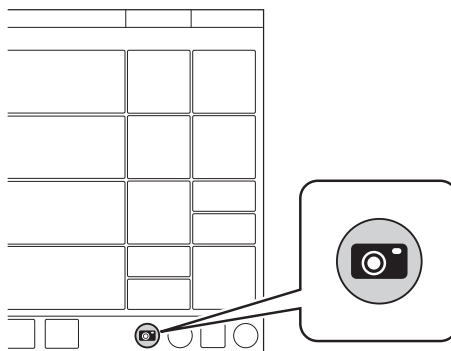

The screenshot will be stamped with the date and time it was taken and saved under the *Saved screens* tab in the *MEDIA* window.

There is space for 40 screenshots under this tab. When the space is full, the next screenshot taken will erase the oldest one.

4.5.2 Viewing saved screens

To view screenshots, tap *MEDIA* in *Saved screens*. Choose the relevant screenshot displayed at the bottom of the window. If there are more than ten screens saved, scroll to the right to find more.

4.5.3 Recording waveforms

To make a recording, tap the recorder (not available in Standby) in the status bar.

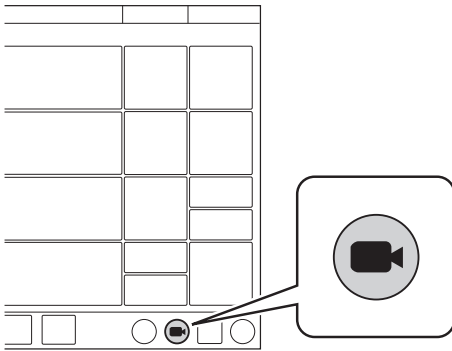

A 30 second long recording will be made starting 15 seconds before, and lasting until 15 seconds after the time the recording was initiated. A blue progress bar will be displayed under the recorder while the recording is being made.

The recording will be stamped with the date and time that it was initiated and will be saved under the *Recordings* tab in the *MEDIA* window. All settings applying at the time the recording is initiated will also be saved.

There is space for 40 recordings under this tab. When the space is full, the next recording made will erase the oldest one.

4.5.4 Viewing recordings

To view recordings, tap *TRENDS & LOGS/MEDIA /Recordings* in the extended menu. Choose the relevant recording displayed at the bottom of the window. If more than ten recordings have been saved, scroll to the right to find more.

The cursor (pale green) is positioned on the dotted line indicating the middle point of the recording. It is activated by moving it or by pressing the arrows to the right of the recorder seen above the dotted line. The values at the cursor position are displayed in digits to the right of the waveform name in the recording window.

When viewing a recording, it is also possible to view the settings by tapping *Settings* at the bottom left of the window. This will open a list of the actual parameter settings in use at the time the recording was initiated.

4.5.5 Exporting and deleting data

To export or delete screenshots or recordings, tap *TRENDS & LOGS/MEDIA /Export & Delete* in the extended menu.

Alternatively, tap the *Export & delete* tab.

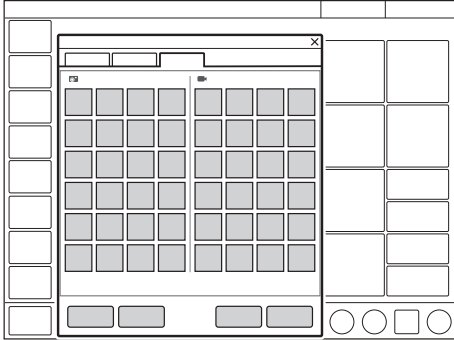

Both screenshots and recordings can be selected for export or deletion.

The additional choice of exporting files that include other material is also given at the bottom right of this window. To use this function, tap *Export files*.

The following data will be exported to a USB memory stick:

- Event log
- Trends
- Saved screens & recordings

Important: Only one USB memory stick may be connected to the USB ports at the same time.

4.6 Ventilator configuration

The ventilator system will always start up with the stored configuration settings.

To view the stored configuration settings, tap *CONFIGURATION* in the extended menu:

The following configurations can be viewed:

- *Alarms*
- *General*
- *Units*
- *Startup configuration*

The alarms configuration can be viewed for each of the patient categories. The other configurations do not vary with patient category.

Note: No editing can be done under *CONFIGURATION*.

Refer to chapter *Service & Settings* on page 123.

4.7 System status

To view the current status of the ventilator system:

- Tap *SYSTEM STATUS* in the quick menu in Standby.
- Tap *SYSTEM STATUS* in the extended menu during ventilation.

The *SYSTEM STATUS* window that opens contains:

1. *Installed options*
2. *General*
3. *Batteries*
4. *Expiratory cassette*
5. *Pre-use check*
6. *O₂ cell*
7. *Patient circuit*
8. Turbine

5 Ventilation modes

Table of contents

5.1	Introduction		56
5.2	Pressure Control (PC)		57
5.3	Pressure Regulated Volume Control (PRVC)		59
5.4	Volume Control (VC)		61
5.5	Bi-Vent/APRV		63
5.6	Pressure Support (PS)/CPAP		65
5.7	Volume Support (VS)		68
5.8	Automode		71
5.9	SIMV		74
5.10	Non Invasive Ventilation (NIV)		78
5.11	NIV Pressure Control (NIV PC)		80
5.12	NIV Pressure Support (NIV PS)		81

5.1 Introduction

5.1.1 Safety guidelines

Not all safety guidelines apply to all modes.

WARNINGS!

- Autotriggering should be avoided. Do not set the trigger level too low.
- The following warning apply to non invasive ventilation (NIV) modes only:
 - Avoid high inspiratory pressure as it may lead to gastric overdistension and risk of aspiration. It may also cause excessive leakage.

Be sure to set alarm limits as appropriate for each mode, especially those for:

- expired minute volume
- apnea time
- airway pressure

Important:

- To protect the patient's lungs from excessive pressure it is important to set the upper pressure limit to a suitable value.
- It is important to avoid leakage so as to ensure the proper functioning of modes such as:
 - PRVC
 - VS
 - Automode PRVC \approx VS
 - SIMV (PRVC) + PS
- The circuit compensation function should be used – it is important to make sure that the compressible volume of the patient circuit is **not** changed after the pre-use check/patient circuit test has been performed (e.g. filling an active humidifier with water or connecting a filter after the test has been performed).

Note:

The ventilator system is delivered preset with the following configuration options:

- Ventilatory settings are based on either minute volume or tidal volume.
- Ventilatory settings are based on either I:E ratio or inspiration time.

5.2 Pressure Control (PC)

Pressure Control (PC):

- delivers a constant pressure over a preset inspiratory time and at a preset respiratory rate
- delivers the inspiration with a decelerating flow
- changes in lung or thorax resistance or compliance will affect the volume delivered

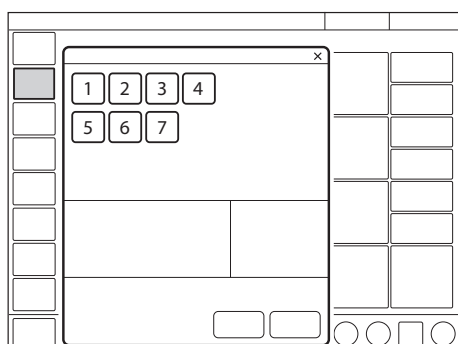

The following parameters are set:

1. Oxygen concentration (%)
2. PEEP (cmH₂O)
3. Respiratory rate (b/min)
4. PC above PEEP (cmH₂O)
5. I:E ratio or Inspiration time (s)
6. Inspiratory rise time (% or s)
7. Trigger

Refer to section Settings on page 41.

The delivered volume is dependent on the pressure above PEEP, lung compliance and resistance in the patient circuit and airways. This means that the tidal volume can vary.

The flow during inspiration is decelerating. The patient can trigger extra breaths. As the delivered tidal volume can vary, it is very important to set alarm limits for the minute volume to adequate levels.

PC ventilation is often preferred when there is leakage in the patient circuit, e.g. due to an uncuffed endotracheal tube, or in situations where the maximum airway pressure must be controlled.

If a patient tries to exhale during inspiration, pressure increases. When it increases 3 cmH₂O above the set inspiratory pressure level, the active expiratory valve opens and regulates the pressure down to the set inspiratory pressure level. If the pressure increases to the set upper pressure limit, e.g. if the patient is coughing, the expiratory valve opens and the ventilator system switches to expiration.

5.2.1 Pressure Control in detail

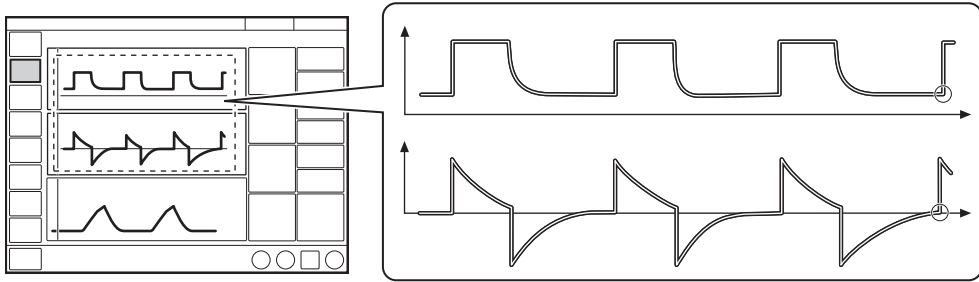

The circles in the figure indicate patient triggering.

- PC ensures that the preset inspiratory pressure level is constant throughout inspiration. Breaths are delivered in accordance with the preset respiratory rate, inspiration time and inspiratory pressure level, resulting in a decelerating flow.
- The preset pressure level is controlled by the ventilator system. The resulting volume depends on the set pressure level, the inspiration time and the mechanical properties of the patient's lungs during each breath.
- Inspiration starts in accordance with the preset respiratory rate or when the patient triggers.

Expiration starts:

- After the termination of the preset inspiration time.
- If the upper pressure limit is exceeded.

5.3 Pressure Regulated Volume Control (PRVC)

Pressure Regulated Volume Control (PRVC):

- combines the advantages of Volume Control and Pressure Control by delivering a preset tidal volume with a decelerating inspiratory flow at a preset respiratory rate
- maintains the lowest possible constant pressure throughout inspiration
- the inspiratory pressure of a breath will never exceed 5 cmH₂O below the upper pressure limit

The ventilator system can be configured so that either tidal volume or minute volume is set.

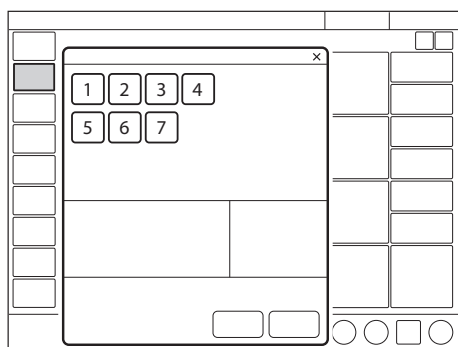

The following parameters are set:

1. Oxygen concentration (%)
2. PEEP (cmH₂O)
3. Respiratory rate (b/min)
4. Tidal volume (ml) or minute volume (l/min)
5. I:E ratio or Inspiration time (s)
6. Inspiratory rise time (% or s)
7. Trigger

Refer to section Settings on page 41.

The ventilator system delivers a preset tidal volume. The pressure is automatically regulated to deliver this volume but limited to 5 cmH₂O below the set upper pressure limit.

The flow during inspiration is decelerating. The patient can trigger extra breaths.

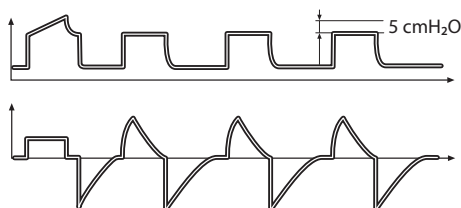

The first breath is a volume controlled test breath with the pause time set to 10 %. The measured pause pressure of this breath is then used as the pressure level for the following breath.

Following the initial breath, the ventilator system calculates and continuously regulates the pressure needed to deliver the preset tidal volume.

An alarm is activated if the set target volume cannot be delivered due to the fact that the pressure required to deliver it is higher than 5 cmH₂O below the set upper pressure limit.

Refer to section Leakage compensation on page 94.

5.3.1 PRVC in detail

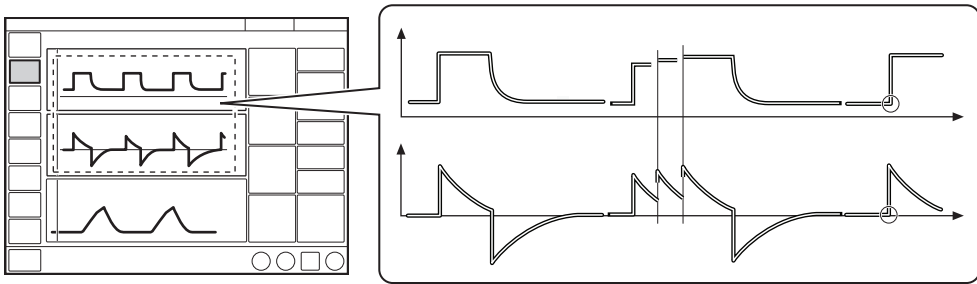

The circles in the figure indicate patient triggering.

- PRVC ensures a set target minute ventilation to the patient. The target volume is based on settings for tidal volume, respiratory rate and inspiration time.
- The inspiratory pressure level is constant during each breath, but automatically adapts in small increments on a breath-by-breath basis to match the mechanical properties of the patient's lungs, thus ensuring delivery of the target volume.
- Inspiration starts in accordance with the preset respiratory rate or when the patient triggers.

Expiration starts:

- After the termination of the preset inspiration time.
- If the upper pressure limit is exceeded.

5.4 Volume Control (VC)

Volume Control (VC):

- delivers a preset tidal or minute volume over a preset inspiratory time and at a preset respiratory rate, regardless of changes in lung or thorax resistance or compliance
- maintains a constant flow with varying peak pressure

The ventilator system can be configured so that either tidal volume or minute volume is set.

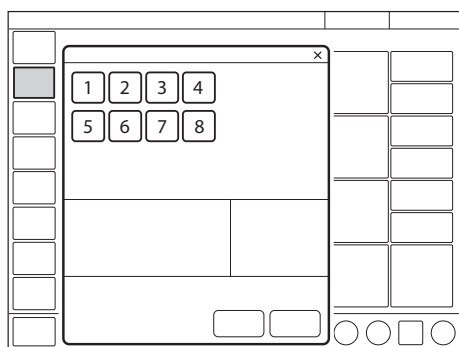

The following parameters are set:

1. Oxygen concentration (%)
2. PEEP (cmH₂O)
3. Respiratory rate (b/min)
4. Tidal volume (ml) or minute volume (l/min)
5. I:E ratio or Inspiration time (s)
6. Pause time (% or s)
7. Inspiratory rise time (% or s)
8. Trigger

Refer to section Settings on page 41.

The airway pressure is dependent on the tidal volume, the inspiration time and the resistance and compliance of the respiratory system. The set tidal volume will always be delivered. An increase in resistance and decrease in compliance will lead to an increased airway pressure. The delivered pressure can vary, so in order to protect the patient's lungs from excessive pressure, it is very important to set the upper pressure limit to a suitable value.

Patients may trigger extra breaths if they can overcome the set trigger level.

Flow adaptation

Patient inspiratory efforts can also result in a higher inspiratory flow and tidal volume than were preset. This is because the ventilator system enables the patient to modify both flow rate and timing.

Thus, if the patient demands a higher flow than the calculated constant flow, the system will sense any sudden pressure drop of > 3 cmH₂O and temporarily enables PS to deliver a higher flow adapted to patient demand.

5.4.1 Volume Control in detail

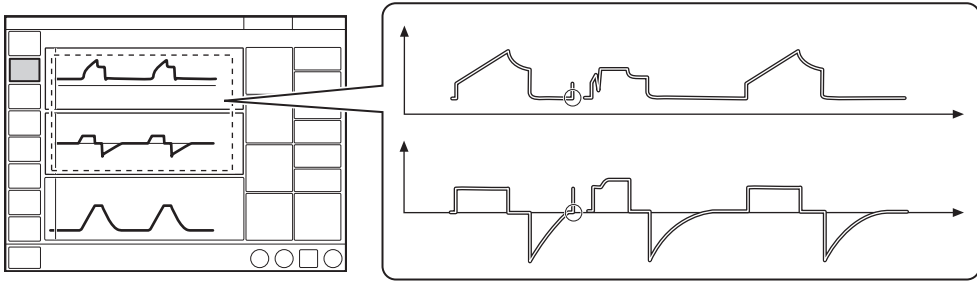

The circles in the figure indicate patient triggering.

- VC ensures a preset tidal volume during a preset inspiratory time at a preset respiratory rate.
 - The inspiratory flow is constant or linearly decelerating and depends on the ventilatory settings.
 - Inspiration starts in accordance with the preset respiratory rate or when the patient triggers.
 - If the patient makes an inspiratory effort during the inspiratory period, when flow adaptation is enabled and flow pattern is 100%, the ventilator system will switch to PS to satisfy the patient's flow demand, as shown in the second breath in the figure.
- Expiration starts:**
- When the preset tidal volume is delivered and after the preset pause time.
 - When the flow returns to the set value after the preset tidal volume is delivered and after the preset pause time (flow adaptation). The patient is however always guaranteed an expiration time corresponding to at least 20 % of the total breath.
 - If the upper pressure limit is exceeded.

5.5 Bi-Vent/APRV

Bi-Vent:

- is a time-cycled, pressure-limited mode that allows spontaneous breathing throughout the entire ventilatory cycle
- has two time-cycled pressure levels and switches between these two levels. The patient can breathe spontaneously at both these levels and it is possible to give Pressure Support at both levels.

Airway Pressure Release Ventilation (APRV):

- is a time-cycled, pressure-limited mode that allows spontaneous breathing throughout the entire ventilatory cycle
- alternates between two levels of positive airway pressure, with the main time on the high level and a brief expiratory release to facilitate ventilation
- differs from Bi-Vent in that it uses an inverse I:E ratio

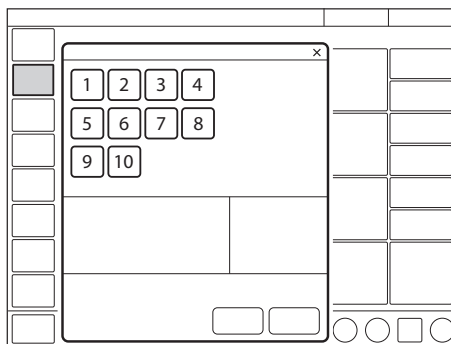

The following parameters are set:

1. Oxygen concentration (%)
2. Pressure at the lower pressure level (PEEP)
3. Pressure at the higher pressure level (P_{high}) (cmH_2O)
4. Time at the higher pressure level (T_{high}) (s)
5. Time at the lower pressure level (T_{PEEP}) (s)
6. PS above P_{high} (cmH_2O)
7. PS above PEEP (cmH_2O)
8. End inspiration (%)
9. Inspiratory rise time (s)
10. Trigger

Refer to section Settings on page 41.

5.5.1 Bi-Vent/APRV in detail

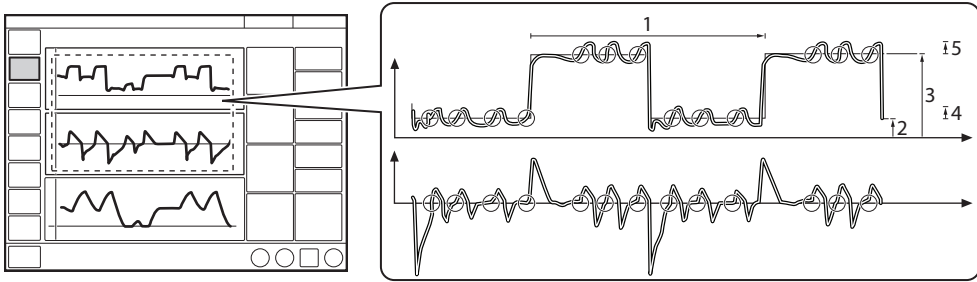

The circles in the figure indicate patient triggering.

1. Bi-Vent/APRV cycle = $T_{high} + T_{PEEP}$
2. PEEP
3. P_{high}
4. PS above PEEP
5. PS above P_{high}

Each Bi-Vent/APRV cycle is regarded as autonomous and therefore most of the measured values are updated every cycle, i.e. minute volume, respiratory rate, mean pressure and end expiratory pressure. Associated alarms are also handled for every cycle.

Bi-Vent/APRV allows for spontaneous breathing/PS ventilation at two different pressure levels. These basic levels are individually set, as well as the time in seconds at each level. The ventilator system always tries to synchronize with the patient's breathing. The main difference between Bi-Vent and APRV is the inverse I:E ratio in APRV.

At extreme settings, the update of measured values and alarms will show a mandatory frequency dependence even in the face of preserved spontaneous breathing.

As a result of switching between two different pressure levels, the tidal volumes may vary significantly between different breaths. This may also be the case for $etCO_2$ (end tidal CO_2) concentration.

Since Bi-Vent/APRV is basically a controlled mode of ventilation, apnea alarm and backup ventilation are not available. It is also very important to set the lower and upper alarm limit for expired minute volume.

5.6 Pressure Support (PS)/CPAP

Pressure Support (PS)/CPAP:

- is initiated by the patient, who controls the respiratory rate and tidal volume
- delivers ventilator support using the preset pressure level and with a decelerating flow
- provides backup (PC) ventilation in case of apnea

Continuous Positive Airway Pressure (CPAP):

- is initiated by the patient and works exactly like PS except that the Pressure Support level is set to zero
- maintains positive pressure in the airways at all times
- is effectively a spontaneous breathing mode with continuous positive pressure to keep the airways open

PS is thus a patient-initiated breathing mode in which the ventilator system supports the patient with a set constant pressure.

The ventilator system provides this constant preset pressure when activated by patient effort. The patient determines the frequency and duration of the breaths, which have a decelerating flow pattern. Duration of inspiration can be adjusted with the help of the *End inspiration* setting.

CPAP may be seen as a special case of PS in which the inspiratory pressure level is set to zero and is used when the patient is breathing spontaneously.

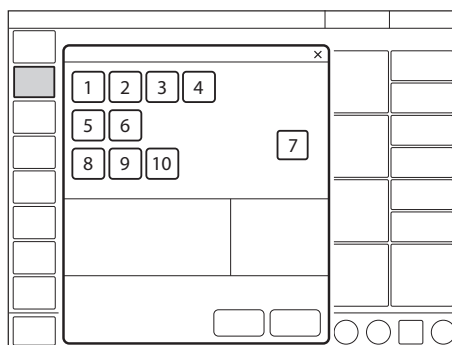

The following parameters are set:

1. Oxygen concentration (%)
2. PEEP (cmH₂O)
3. PS above PEEP (cmH₂O) (PS level)
4. End inspiration (%)
5. Inspiratory rise time (s)
6. Trigger
7. Apnea time (s)
8. Backup respiratory rate (b/min)
9. Backup PC above PEEP (cmH₂O)
10. Backup I:E or Ti (s)

Refer to section Settings on page 41.

The higher the preset inspiratory pressure level from the ventilator system, the more gas flows into the patient. As the patient becomes more active, the PS level may be gradually reduced.

Always set the apnea time that is appropriate to the individual patient situation. If the apnea alarm limit is reached, the ventilator system will automatically switch to backup ventilation (PC).

The alarm should alert staff to take action by either returning to a supported mode or changing to a controlled mode of ventilation.

It is also very important to set the lower and upper alarm limits for expired minute volume.

The inspiratory rise time should be set to a comfortable value for the patient. In PS, the inspiratory rise time should normally be increased.

The *End inspiration* setting is important to patient comfort and ventilator synchronization with the patient. If the patient's expiratory resistance is high, the *End inspiration* setting should be raised to guarantee enough time for expiration.

It is important to monitor how this affects the tidal volume.

5.6.1 PS/CPAP in detail

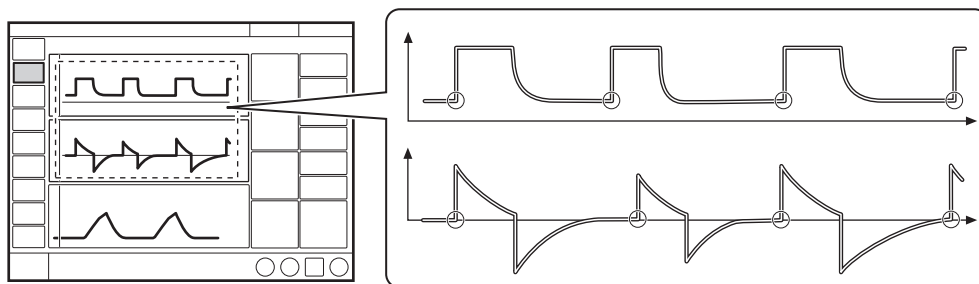

The circles in the figure indicate patient triggering.

- PS ensures that a preset inspiratory pressure level is constantly maintained in response to patient effort.
 - The preset pressure level is controlled by the ventilator system, while the patient determines the respiratory rate and inspiration time.
 - Inspiration starts when the patient triggers a breath and gas flows into the lungs at a constant pressure. Since the pressure provided by the ventilator system is constant, the flow will decrease until the level set for *End inspiration* is reached.
 - For CPAP, inspiration starts upon patient effort.
- Expiration starts:**
- When the inspiratory flow decreases below a preset fraction of the peak inspiratory flow (*End inspiration*)
 - If the upper pressure limit is exceeded
 - If the maximum time for inspiration is exceeded
- Refer to section Functions in ventilation modes on page 146.
- If the flow drops to a range between 25 % of peak flow and the lower limit for *End inspiration*, and remains within the range for a period longer than 50% of the time elapsing between inspiration start and the point when the range was entered.

5.7 Volume Support (VS)

Volume Support (VS):

- is initiated by the patient, who controls the respiratory rate
- delivers ventilator support with a variable peak pressure and decelerating flow to guarantee the preset tidal volume
- the inspiratory pressure of a breath will never exceed 5 cmH₂O below the upper pressure limit
- provides backup (PRVC) ventilation in case of apnea

A patient-adapted constant inspiratory support is supplied when activated by patient effort. The resulting volume is continuously monitored and the constant inspiratory pressure automatically adjusts to the required level. The patient determines the frequency and duration of the breaths which have a decelerating flow pattern.

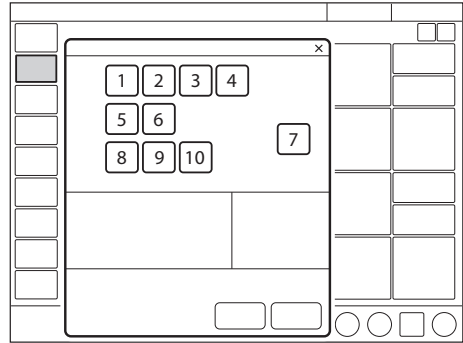

The following parameters are set:

1. Oxygen concentration (%)
2. PEEP (cmH₂O)
3. Tidal volume (ml)
4. End inspiration (%)
5. Inspiratory rise time (s)
6. Trigger
7. Apnea time (s)
8. Backup respiratory rate (b/min)
9. Backup tidal volume (ml)
10. Backup I:E or Ti (s)

Refer to section Settings on page 41.

If patient activity increases, the inspiratory support will decrease provided that the set tidal volume is maintained. If the patient breathes below the set tidal volume, the inspiratory support will increase.

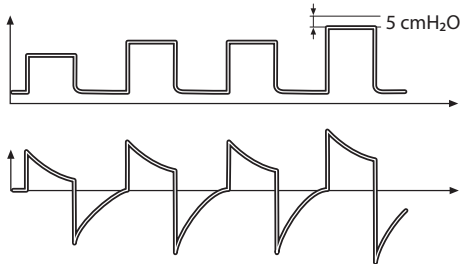

The initial breath provides support with 5 cmH₂O.

Following this breath, the ventilator system calculates and continuously regulates the pressure needed to deliver the preset tidal volume.

An alarm is activated if the set target volume cannot be delivered due to the fact that the pressure required to deliver it is higher than 5 cmH₂O below the set upper pressure limit.

In this mode it is also important to set the apnea time that is appropriate to the individual patient's situation. If this time is reached, the ventilator system will automatically switch to backup ventilation.

Refer to section Leakage compensation on page 94.

5.7.1 Volume Support in detail

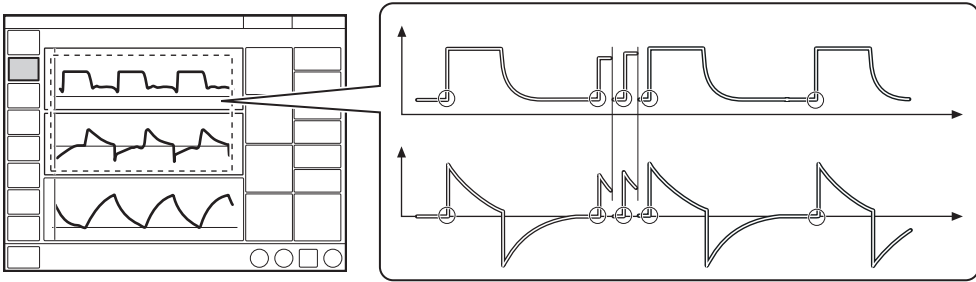

The circles in the figure indicate patient triggering.

- VS ensures delivery of a set target tidal volume following patient effort by providing inspiratory pressure support that is adapted to the patient.
 - The inspiratory pressure level is constant during each breath, but alters in small increments, on a breath-by-breath basis, to match the patient's breathing ability and the mechanical properties of the lungs.
 - Inspiration starts when the patient triggers.
- Expiration starts:**
- When the inspiratory flow decreases below a preset fraction of the peak inspiratory flow (*End inspiration*)
 - If the upper pressure limit is exceeded
 - If the maximum time for inspiration is exceeded
Refer to section Functions in ventilation modes on page 146.
 - If the flow drops to a range between 25 % of peak flow and the lower limit for End inspiration, and remains within the range for a period longer than 50% of the time elapsing between inspiration start and the point when the range was entered.

5.8 Automode

In Automode, the ventilator system shifts automatically between controlled and supported ventilation, allowing better patient-ventilator interaction. When the patient is making a breathing effort, the ventilator system immediately switches to a supported mode of ventilation. If the patient is not making any breathing effort, the ventilator system will return to the controlled mode and deliver controlled breaths.

The parameters for each Automode combination are adjusted in the settings window and are basically the same as those for the relevant controlled or supported mode. Refer to section Settings on page 41.

Automode PC ⇄ PS:

- is an interactive mode automatically switching between the controlled mode PC and supported mode PS based on patient triggering
- delivers controlled breaths in the absence of patient breathing effort, switching to supported breaths when a breathing effort is detected
- serves as an aid to starting the weaning period
- adapts to the patient's breathing capacity

Automode PRVC ⇄ VS:

- is an interactive mode automatically switching between the controlled mode PRVC and supported mode VS based on patient triggering
- delivers controlled breaths in the absence of patient breathing effort, switching to supported breaths when a breathing effort is detected
- serves as an aid to starting the weaning period
- adapts to the patient's breathing capacity

In this combination, the first supported breath delivered to the patient has the same pressure level as the preceding PRVC breath.

Automode VC ⇄ VS:

- is an interactive mode automatically switching between the controlled mode VC and supported mode VS based on patient triggering
- delivers controlled breaths in the absence of patient breathing effort, switching to supported breaths when a breathing effort is detected
- serves as an aid to starting the weaning period
- adapts to the patient's breathing capacity

In this combination, the ventilator system uses the plateau pressure in the VC breath as a reference pressure for the first VS breath.

5.8.1 Automode in detail

1. The ventilator system starts in PC, PRVC or VC mode. If the patient triggers a breath, the ventilator system will turn to the relevant supported mode to encourage the patient's respiratory drive.
2. If the patient is breathing adequately:
 - a. In VS, the ventilator system adjusts the inspiratory pressure level on a breath-by-breath basis to ensure delivery of the preset target volume.
 - b. In PS, the ventilator system ensures that the preset inspiratory pressure level is maintained throughout inspiration.
3. The ventilator system initially adapts with an increasing apnea time. This means that for the spontaneously triggering patient, the apnea time increases successively until the level set in the settings window for the maximal apnea time parameter is reached after 10 consecutive spontaneously triggered breaths. Refer to section Settings on page 41.
4. Exceeding the maximal apnea time setting without a sufficient patient effort will cause the following:
 - a. In VS, a PRVC or VC breath will be delivered according to the selected Automode functionality.
 - b. In PS, a PC breath will be delivered.
5. The rings in the figures indicate patient triggering.

PC ⇌ PS

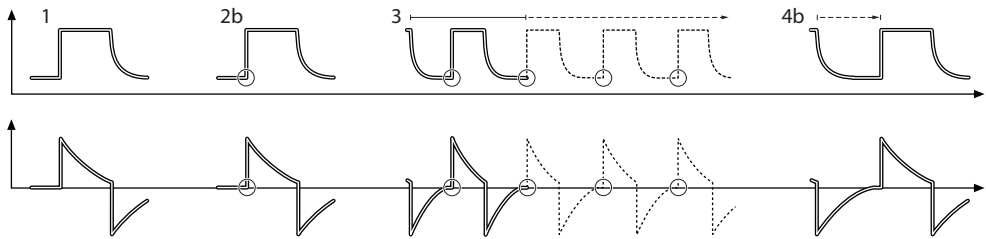

PRVC ⇌ VS

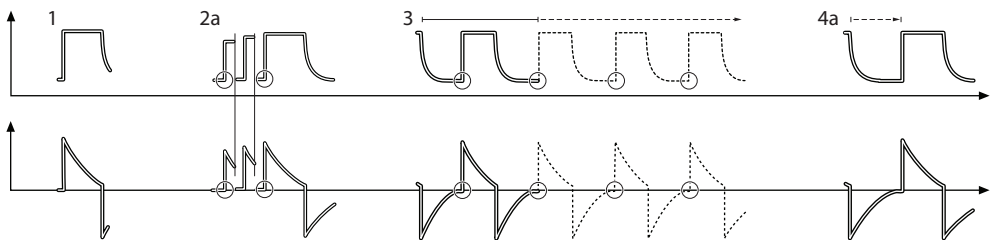

In the Automode PRVC ⇌ VS combination, the first supported breath delivered to the patient has the same pressure level as the preceding PRVC breath.

VC ⇌ VS

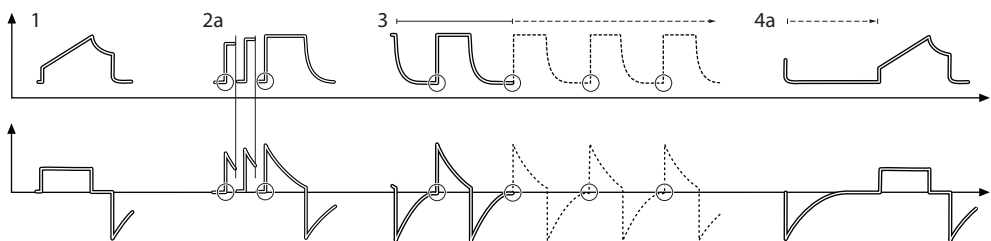

In the Automode VC ⇌ VS combination, the ventilator system uses the plateau pressure in the VC breath as a reference pressure for the first VS breath.

5.9 SIMV

SIMV stands for Synchronized Intermittent Mandatory Ventilation. In SIMV modes, mandatory controlled ventilation breaths are delivered with a preset SIMV rate. The patient can breathe spontaneously with PS between the mandatory breaths.

The parameters for each SIMV combination are adjusted in the settings window and are basically the same as those for the relevant controlled or supported mode.

Refer to section Settings on page 41.

SIMV (PC) + PS:

- delivers mandatory controlled breaths using a preset respiratory rate and a preset pressure
- delivers inspiratory support (PS) during spontaneous breaths taken between the mandatory breaths

SIMV (PRVC) + PS:

- delivers mandatory controlled breaths using a preset respiratory rate and a preset volume
- delivers inspiratory support (PS) during spontaneous breaths taken between the mandatory breaths

SIMV (VC) + PS:

- delivers mandatory controlled breaths using a preset respiratory rate and a preset volume
- delivers inspiratory support (PS) during spontaneous breaths taken between the mandatory breaths

In SIMV modes, the mandatory breath is defined by the basic settings.

Settings

	SIMV (PC) + PS	SIMV (PRVC)+PS	SIMV (VC)+ PS
PC above PEEP	X	—	—
Tidal volume /Minute volume	—	X	X
SIMV rate	X	X	X
Breath cycle time	X ¹	X ¹	X ¹
I:E ratio / Inspiration time	X	X	X
Insp. rise time	X	X	X
Pause time	—	—	X ¹

¹ Only when the ventilator system is configured for setting the I:E ratio.

Note: In the minute volume configuration, the tidal volume is determined by dividing the minute volume by the SIMV rate.

The breath cycle time is the length of the mandatory breath in seconds and is the same as the duration of an SIMV period.

In SIMV, the very first breath is always a mandatory one.

If the patient triggers a breath during the SIMV period, the breath delivered is a mandatory one. If the patient fails to trigger a breath within the first 90 % of the SIMV period, a mandatory breath is delivered.

Note: If the ventilator system is configured for setting the inspiration time, an I:E ratio of 1:2 will be used to estimate the breath cycle time.

The spontaneous/Pressure Support breaths are defined by setting the level for Pressure Support above PEEP (PS above PEEP).

5.9.1 SIMV in detail

- This combination of controlled and supported ventilation allows for preset mandatory breaths that are synchronized with the patient's breathing.
- If there is no trigger attempt within a time window equal to 90 % of the set breath cycle time, a mandatory breath is delivered (the breath cycle time is the total time for one mandatory breath).
- The mandatory breath is defined by the basic settings (mode of ventilation, breath cycle time, respiratory pattern and volumes/pressures).
- The spontaneous/supported breaths are defined by the setting for PS.

5.9.2 SIMV (PC) + PS

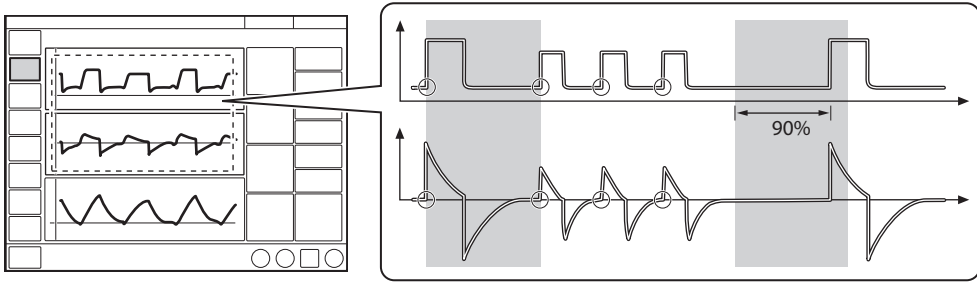

The circles in the figure indicate patient triggering.

5.9.3 SIMV (PRVC) + PS

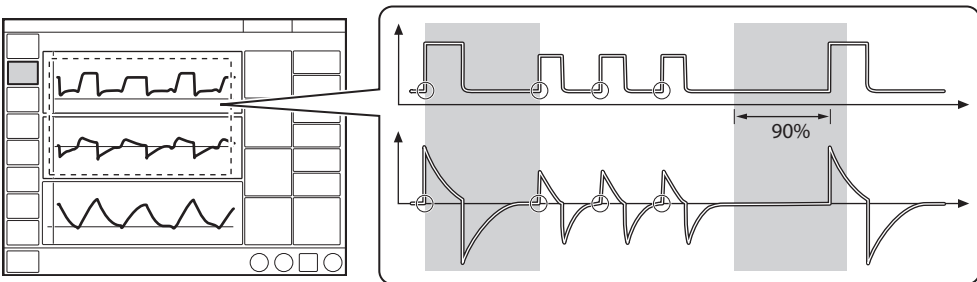

The circles in the figure indicate patient triggering.

5.9.4 SIMV (VC) + PS

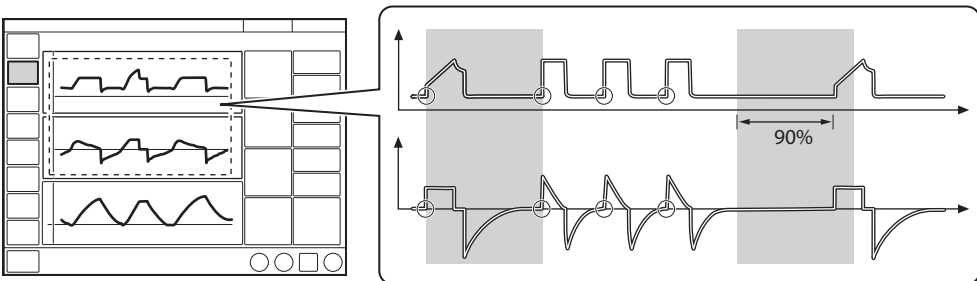

The circles in the figure indicate patient triggering.

5.10 Non Invasive Ventilation (NIV)

5.10.1 Safety guidelines

WARNINGS!

- Avoid high inspiratory pressure as it may lead to gastric overdistension and risk of aspiration. It may also cause excessive leakage.
- The dead space will increase in NIV when using a mask or helmet.
- NIV is not intended to be used on intubated or tracheotomized patients.
- In non invasive ventilation, the measured expired volume may be different from the actual volume exhaled by the patient due to leakage around the mask.
- If nasal prongs are used, make sure that they are applied so that air can flow freely through both prongs.

CAUTIONS:

- It is not recommended to use a nebulizer during NIV as the nebulized drug might come in contact with the patient's eyes in case of leakage.
- Mask/prongs leakage might affect nebulizer efficiency.

Important:

- The mask/prongs must be properly applied in order to minimize leakage.
- When selecting the mask/prongs, it is essential to consider such things as proper size and accurate adaptation to the patient.

- CO₂ rebreathing will increase during NIV and use of a face mask/prongs.

5.10.2 Introduction

NIV refers to ventilation when the patient is not intubated or tracheotomized. It involves the use of a patient interface such as:

- nasal mask
- nasal prongs
- face mask
- total face mask
- endotracheal tube positioned above the vocal cords
- NIV helmet

In NIV, the ventilator system adapts to variations in leakage to maintain the required pressure and PEEP level. Excessive leakage will result in a high priority alarm. Ventilation will resume automatically if the leakage decreases. It can also be started manually by tapping *Resume ventilation* in the *LEAKAGE DETECTED* window that opens to inform about leakage.

Note: In NIV, flow and volume curves and the following measured values are compensated for leakage: VT_i, VT_e, MV_i, MV_e.

Refer to chapter Alarm handling on page 109.

In all NIV modes, there is an automatic detection of patient connection and disconnection – the NIV disconnection functionality. This ensures that ventilation starts in a comfortable manner when the patient interface is applied to the patient's face. It ensures that ventilation stops when the interface is removed, avoiding high air flows and alarms.

It is possible to configure the NIV disconnection functionality. The setting made here will ensure a constant disconnection flow while ventilation is paused (at a high flow or a low flow setting). It is also possible to disable the NIV disconnection functionality, which may result in high air flows and alarms.

Refer to chapter Service & Settings on page 123.

5.10.3 Using a NIV helmet

WARNING!

The helmet application shall not be used with volume controlled modes.

The helmet application must only be used with pressure supported ventilation in NIV.

Important:

- When using NIV PS, the filling of the helmet **must** be initiated by tapping *START VENTILATION* or *Resume ventilation* on the screen. This must also be done after disconnection.
- To secure a proper patient triggering function, the PEEP level should never be set below 3 cmH₂O. When helmets with a safety valve are used, it is recommended to set a PEEP level of at least 5 cmH₂O.

- Alarms related to volume are not reliable. To avoid nuisance alarms the alarm limits must be properly set.
- It is essential to set pressure alarms adequately.

It is possible to use a helmet for non invasive ventilation of patients between 10 and 250 kg. Only use the adult patient category when using a helmet.

For instructions for the helmet application, refer to the manufacturer's instructions for use.

There are a few points to remember in order to use a helmet safely:

- Do **not** rely on flow and volume parameters.
- The volume in the helmet may cause delays in signals and patient triggering.
- Make sure that the helmet used eliminates CO₂ re-breathing.
- High pressure levels may affect the patient's ears and the flow may affect the patient's eyes.
- Patients may perceive the helmet application as noisy. A Servo Duo Guard filter used on the inspiratory side will reduce the noise level. The noise level may vary between different helmets.
- Do not use humidified ventilation gas as this will cause condensation on the helmet walls.
- Do not use nebulizers.

5.11 NIV Pressure Control (NIV PC)

NIV Pressure Control (NIV PC):

- delivers a constant pressure over a preset inspiratory time and at a preset respiratory rate
- delivers the inspiration with a decelerating flow
- changes in lung or thorax resistance or compliance will affect the volume delivered
- is leakage compensated

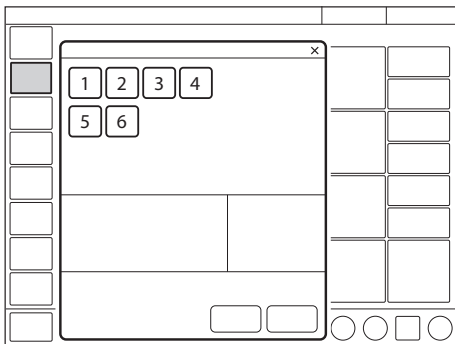

The following parameters are set:

1. Oxygen concentration (%)
2. PEEP (cmH₂O)
3. Respiratory rate (b/min)
4. PC above PEEP (cmH₂O)
5. I:E ratio or Inspiration time (s)
6. Inspiratory rise time (% or s)

Refer to section Settings on page 41.

Differences compared with invasive PC:

- When *START VENTILATION* is tapped, a waiting position dialog is displayed. All patient related alarms are turned off for 2 minutes. In this position, ventilation will start if the ventilator system detects patient activity.
- The trigger cannot be manually set in NIV.
- Detection of pressure below PEEP or expiratory volume decrease will start a new breath.

5.12 NIV Pressure Support (NIV PS)

NIV Pressure Support (NIV PS):

- is initiated by the patient, who controls the respiratory rate and tidal volume
- delivers ventilator support using the preset pressure level and with a decelerating flow
- has a fixed trigger
- provides backup (PC) ventilation in case of apnea
- is leakage compensated

Differences compared with invasive PS:

- When *START VENTILATION* is tapped, a waiting position dialog is displayed. All patient related alarms are turned off for 2 minutes. In this position, ventilation will start if the ventilator system detects patient activity.
- The ventilator system will not lock in backup ventilation. There is no limit on the number of times the ventilator system can switch between supported mode and backup.
- The trigger cannot be manually set in NIV.

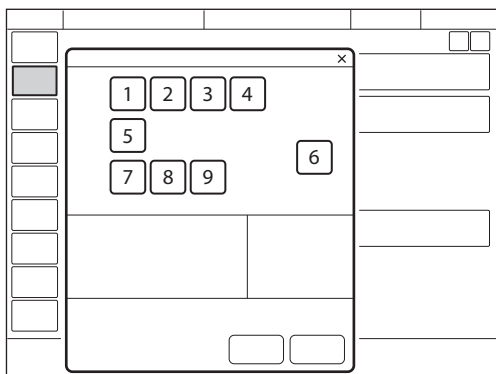

The following parameters are set:

1. Oxygen concentration (%)
2. PEEP (cmH₂O)
3. PS above PEEP (cmH₂O) (PS level)
4. End inspiration (%)
5. Inspiratory rise time (% or s)
6. Apnea time (s)
7. Backup respiratory rate (b/min)
8. Backup PC above PEEP (cmH₂O)
9. Backup I:E or Ti (s)

Refer to section Settings on page 41.

6 Ventilatory settings and functions

Table of contents

6.1	O ₂ concentration		84
6.2	Tidal volume/Minute volume		84
6.3	Pressure level		84
6.4	I:E ratio/Inspiration time		85
6.5	End inspiration		86
6.6	Inspiratory rise time		87
6.7	Trigger		88
6.8	Apnea time		90
6.9	SIMV breath cycle time		90
6.10	Predicted body weight (PBW)		91
6.11	Maneuvers		91
6.12	Compensation functions		94
6.13	Disconnection/Suction		95
6.14	Previous mode		97
6.15	Apnea management		98
6.16	Nebulization		101
6.17	Adjust the O ₂ cell		107

6.1 O₂ concentration

The O₂ concentration delivered to the patient is set in the mode settings window and is monitored by the ventilator system with upper and lower alarm limits.

Refer to section Alarm limits on page 145.

The alarm is delayed 40 seconds after changing the O₂ concentration.

6.2 Tidal volume/Minute volume

Depending on the ventilator configuration, the inspiratory volume can be set as either:

- tidal volume or
- minute volume

Whichever of these is set, the other will be displayed in the lower right information area of the mode settings window.

6.3 Pressure level

PC above PEEP is the set inspiratory pressure level for each mandatory breath in:

- PC
- SIMV (PC) + PS
- Automode PC ⇌ PS
- backup ventilation in PS

PS above PEEP is the set inspiratory pressure support level for triggered breaths in:

- PS
- all SIMV modes
- Automode PC ⇌ PS
- Bi-Vent

6.4 I:E ratio/Inspiration time

The setting of ventilatory settings can be configured in two different ways, based on:

- I:E ratio or
- inspiration time, in seconds, to better meet the requirements for pediatric care.

6.4.1 I:E ratio

The I:E ratio expresses the relation between the inspiration phase and the expiration phase. Spontaneous breathing has an I:E ratio of around 1:1.5.

Note that increasing the inspiration time may raise mean airway pressure and improve oxygenation but may also cause hyperinflation. Reversed I:E ratios (e.g. 1.5:1 or 2:1) will further lengthen inspiratory time and shorten expiration, which may be helpful if the lungs are very stiff, but requires low respiratory rates to avoid gas trapping.

A prolonged expiration time (e.g. 1:3) may be used for weaning and in case of obstructive lung disease, but a short inspiration time may also lower the tidal volume and lead to inadequate ventilation.

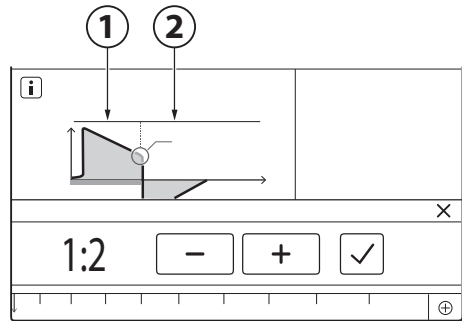

1. Inspiration
2. Expiration

An inverse I:E ratio is also used in Bi-Vent/APRV mode.

Refer to section Bi-Vent/APRV on page 63.

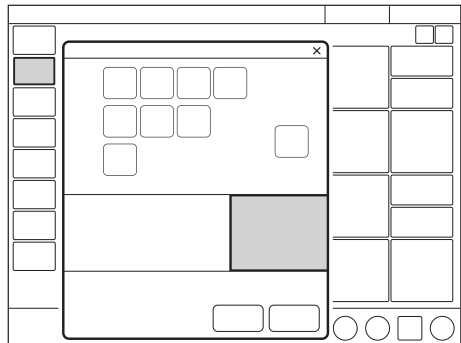

When the ventilator system is configured for setting of I:E, the unit for pause time and inspiratory rise time automatically switches to percent. The corresponding inspiration time for each I:E is displayed in the lower right information area of the mode settings window.

6.4.2 Inspiration time

The setting makes it possible to set the inspiration time (T_i) to a fixed time in seconds.

With this configuration, the unit for inspiratory rise time and pause time automatically switches to seconds. The corresponding I:E ratio for each inspiration time setting is displayed in the lower right information area of the mode settings window.

As the inspiration time is explicitly set, a change in the respiratory rate, for example, will affect the I:E ratio. As a safety precaution, there will therefore be an indication when the resulting I:E ratio passes 1:1 in either direction.

Note: When the inspiration time is directly set, the breath cycle time parameter is not displayed when an SIMV mode is selected, since there is no need to set it.

6.5 End inspiration

End inspiration:

- is the point at which inspiration changes to expiration in supported ventilation
- if set too low, inspiration will be longer, which may cause pulmonary hyperinflation and increased work of breathing
- if set too high, inspiration will be shorter, which may mean that the patient receives insufficient tidal volume

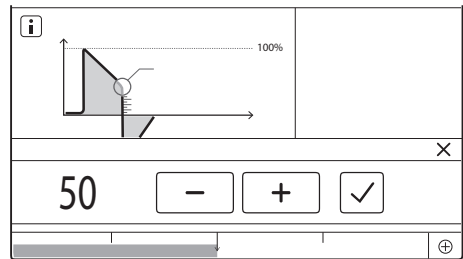

6.6 Inspiratory rise time

The inspiratory rise time ($T_{insp.rise}$):

- is the time taken to reach peak inspiratory flow or pressure at the start of each breath
- is expressed in seconds or as a percentage of the respiratory cycle time depending on how the ventilator is configured

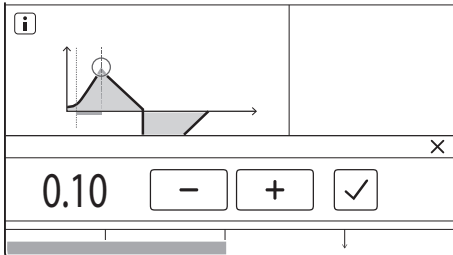

An increased inspiratory rise time will affect the rate of flow/pressure increase and can be evaluated by the shape of the flow and pressure waveforms.

In supported modes, the inspiratory rise time should normally be increased from the default setting to enhance patient comfort.

Inspiratory rise time set as a percentage is applicable in:

- VC
- PC
- PRVC
- all SIMV modes
- all Automode modes

Inspiratory rise time set in seconds is applicable in:

- PS
- VS
- Bi-Vent/APRV

Note: When the ventilator system is configured for setting of inspiration time rather than I:E ratio, the unit for inspiratory rise time automatically switches to seconds for all ventilation modes.

6.7 Trigger

6.7.1 Pneumatic trigger

WARNING! If the flow trigger level is very low (too far to the left on the scale), an autotriggering condition may be reached. This condition can also be reached if there is leakage in the patient circuit, e.g. if an uncuffed endotracheal tube is used. Triggering will then be initiated by the ventilator system and not by the patient. This should always be avoided by increasing the patient effort required to trigger the ventilator system, moving further to the right on the scale.

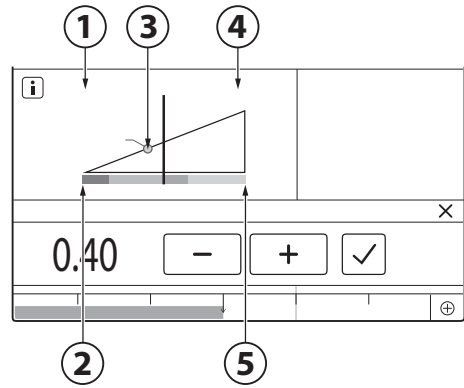

1. Flow
2. Less effort
3. Trigger setting
4. Pressure
5. More effort

The ventilator system has a pneumatic trigger (flow or pressure based) functionality.

The pneumatic trigger setting:

- determines the level of patient effort needed to trigger the ventilator to inspiration
- may be set as either flow or pressure triggering, where flow triggering allows the patient to breathe with less effort
- should generally be set so that it requires minimal patient effort without causing autotriggering

During expiration, the ventilator system continuously delivers a gas flow (bias flow), which is measured in the expiratory channel.

Refer to section Ventilatory settings on page 142.

When triggering is based on flow, to the left on the scale, the ventilator system senses deviations in the bias flow delivered during expiration. These deviations are caused by the inspiratory efforts of the patient.

The further to the left on the scale, the less effort the patient has to make. At the far left of the scale, there is a risk of autotriggering, and the scale and value are therefore marked in red. The trigger setting is marked with a ring in the dynamic image.

When triggering is based on pressure, to the right on the scale, the ventilator system senses deviations in the pressure below PEEP created by the patient. The pressure below PEEP required to initiate a breath is displayed when the setting is made.

The further to the right on the scale, the greater the patient effort required to trigger.

The trigger scale has different colors based on the setting. Green indicates a normal setting for pneumatic triggering. Red indicates that the setting is not recommended, e.g. when the risk of autotriggering may increase. Yellow is used as a warning color.

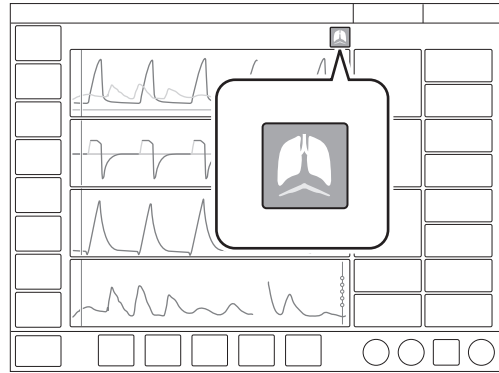

Patient triggering (flow or pressure) is indicated by a symbol in the status bar.

The pressure or flow curve will also be highlighted in white depending on which type of trigger is used.

6.8 Apnea time

Apnea time is the time without a patient breathing effort that the ventilator system will allow to elapse in supported ventilation before the *No patient effort* alarm is activated and the ventilator system switches to the backup mode.

Refer to section Apnea management on page 98.

6.8.1 Maximal apnea time

The maximal apnea time:

- is the maximum time without a patient breathing effort that the ventilator will allow to elapse in supported ventilation before switching to controlled ventilation.

In Automode, the apnea time becomes longer as spontaneous breathing becomes more regular. It is therefore set, in Automode only, as *Max. apnea time*.

6.9 SIMV breath cycle time

The SIMV breath cycle time:

- is the duration of the total respiratory cycle of the mandatory breath in SIMV (inspiration + pause + expiration)
- only applies if the inspiratory time is set using the I:E ratio
- together with a spontaneous period, makes up one full SIMV cycle

The breath cycle time is sometimes referred to as an SIMV period.

Note: The breath cycle time parameter is not displayed when an SIMV mode is selected and inspiration time is configured.

6.10 Predicted body weight (PBW)

Notes:

- For adult patients outside the height range 130-200 cm, PBW is the same as the patient weight (BW).
- For pediatric patients, PBW is the same as the patient weight (BW).

In mechanical ventilation, predicted body weight can be used to help reduce the risk that differences in body weight will affect the estimated ventilation needs of different patients.

The ventilator monitors the ratio of tidal volume to PBW (VT/PBW) in ml/kg.

In the adult patient category PBW is calculated according to the Devine Formula and requires that height and gender are entered.

The tidal volume setting will, when tapped, present a calculated value for VT/PBW if the necessary patient data has been entered under *PATIENT DATA*. The value will also be presented in the numerical values and trended under *TRENDS & LOGS/TRENDS*

6.11 Maneuvers

The following four functions can be accessed under *MANEUVERS* (only available during ventilation) in the quick menu.

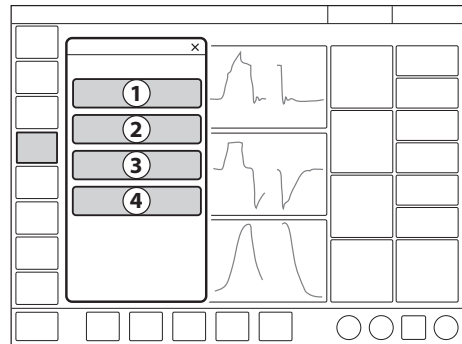

1. Manual breath
2. Static measurements
3. Nebulization
4. O₂ boost level

6.11.1 Manual breath

When *MANUAL BREATH* is tapped, the ventilator system will initiate a new breath cycle according to the current ventilator settings.

6.11.2 Static measurements

The inspiratory and expiratory hold can be used to perform certain measurements:

- PEEP_{tot}: set PEEP + intrinsic PEEP
- C_{static}: static compliance, a measure of the elastic properties of the respiratory system. A decrease in compliance implies stiffer lungs.
- E: elastance, has different compliances and resistances in the lungs and an increase in elastance implies stiffer lungs.
- R_i: inspiratory resistance
- R_e: expiratory resistance
- T_c: time constant, calculated as C_{static} x R_e. Some lung units have decreased compliance, and some have increased resistance, or both. Differences in R_e and C_{static} affect the speed at which the lung units are filled and emptied. An expiration time of three time constants is recommended to avoid auto PEEP.
- P_{plat}: pressure during end inspiratory pause

Inspiratory hold

This function is activated by pressing *INSPIRATORY HOLD* for a maximum of 30 seconds. The inspiratory and expiratory valves close after inspiration. This function can provide an exact measurement of the end inspiratory lung pressure. It can be used to pause ventilation during X-ray or to determine the plateau pressure (P_{plat}), or, together with the expiratory hold, to calculate static compliance.

Expiratory hold

Expiratory and inspiratory valves are closed after the expiration phase is completed for as long as *EXPIRATORY HOLD* is pressed, but only up to a maximum of 30 seconds. Expiratory hold provides an exact measurement of the end expiratory pause pressure. It can be used to determine total PEEP and, together with inspiratory hold, static compliance (C_{static}). The dynamic pressure is displayed on the PEEP numerical value.

6.11.3 Nebulization

Refer to section Nebulization on page 101.

6.11.4 O₂ boost level

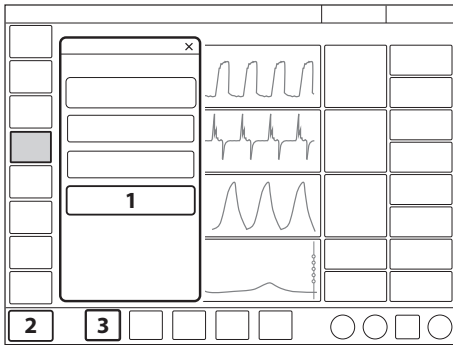

1. O₂ boost level
2. O₂ boost function
3. O₂ concentration setting (*O₂ conc.*)

By tapping O₂ BOOST LEVEL, it is possible to change the desired level for the O₂ boost function. It is possible to lock the O₂ boost level to 100 %. It is also possible to set it to 0 %, in which case the O₂ boost function will no longer be active and will be replaced by three asterisks.

The value entered under *O₂ boost (%) level* specifies the number of percentage units that will be added to the value set for the O₂ concentration.

For example: if the current O₂ concentration is 40 % and the O₂ boost level is 30 %, the O₂ boost function will, when tapped, deliver 70 % O₂.

The O₂ boost function figure displayed will change accordingly. Since the minimum O₂ concentration is 21 %, the *O₂ boost (%) level* scale goes from 0 to 79 %.

Refer to section Ventilatory settings on page 142 and to section Edit Temporary O₂ increase (%) on page 127.

6.11.5 O₂ boost function

To use the O₂ boost function, tap and hold O₂ boost at the bottom left corner of the screen.

When tapped, O₂ boost delivers the oxygen setting displayed here for a period of 1 minute. The O₂ boost function can be interrupted by tapping the red cancel symbol in the O₂ boost timer window anytime during the 1 minute interval.

6.12 Compensation functions

6.12.1 Leakage compensation

Leakage compensation is automatic for all patient categories in non invasive modes.

The function is designed to help maintain PEEP throughout the breath and is activated by default.

Leakage compensation may also affect important ventilatory parameters, such as patient triggering and the termination of inspiration.

Leakage is measured and presented in percent.

6.12.2 Circuit compensation

Part of the volume of each inspiration will not reach the patient because of gas compression in the ventilator and expansion of the tubing. All components in the patient circuit affect such losses.

When circuit compensation is activated, the delivered and measured volume and flow values are automatically compensated for these losses, as indicated by the symbols on the affected values.

The patient circuit test must be passed in order to activate circuit compensation.

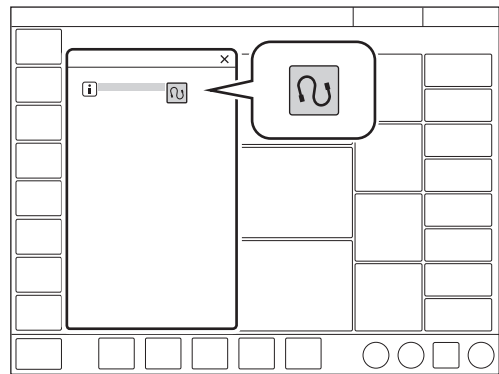

To deactivate or reactivate, tap *COMPENSATION* in the extended menu/*CIRCUIT COMPENSATION*. Follow on-screen instructions.

Important: When monitoring VT/PBW, circuit compensation must be activated.

6.13 Disconnection/Suction

Important: If a closed-suction system is used, *DISCONNECTION/SUCTION*, as well as the inspiratory and expiratory hold functions, should **not** be used.

Tap *DISCONNECTION/SUCTION* in the quick menu during ventilation to open the *DISCONNECTION/SUCTION* window.

The window always opens in *Preparation*.

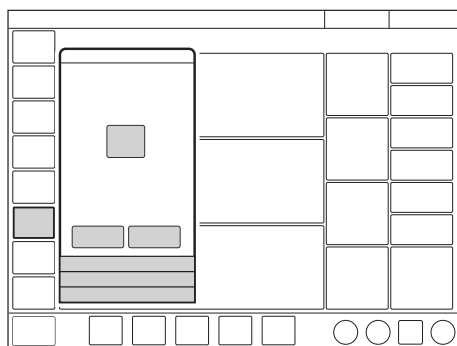

DISCONNECTION/SUCTION enables automatic inhibition of the ventilator system during a tracheal suction procedure or when briefly pausing ventilation in invasive modes. The ventilator system is prevented from cycling without activating alarms.

Refer to section Ventilatory settings on page 142 and to section Edit Temporary O₂ increase (%) on page 127.

6.13.1 Suctioning procedures

Open suctioning

Important:

- Alarms are turned off during the *Patient disconnected* phase for a maximum of 60 seconds. If the patient has not been reconnected within 60 seconds, alarms are activated.
- The minimum PEEP level during disconnection is 3 cmH₂O. The ventilator system will adjust to the minimum level if the PEEP level is below 3 cmH₂O in order to detect disconnection of the patient.

For open suctioning procedures, there are three phases following *Preparation*:

- *Pre-oxygenation*
- *Patient disconnected*
- *Post-oxygenation*

Notes:

- *DISCONNECTION/SUCTION* is not available in NIV modes or when *Manual breath* is activated.
- During the *Patient disconnected* phase of a suctioning procedure, the nebulizer is temporarily paused.
- When only one gas is connected, an elevated oxygen level cannot be set during the preparation phase. In this case, the post-oxygenation phase will be skipped.

Adjust the O₂ concentration, if desired, then tap *Accept*.

Note: Tapping *Cancel* will close the *DISCONNECTION/SUCTION* window.

- *Pre-oxygenation*

Pre-oxygenation of the patient begins automatically after *Accept* is tapped during preparation.

The *Patient circuit disconnected* alarm is turned off. The maximum duration of the pre-oxygenation phase is 120 seconds. After this, the system automatically returns to ventilation using the previous oxygen setting. The same thing happens if *Cancel* is tapped.

- *Patient disconnected*

The system automatically enters the *Patient disconnected* phase when the patient is disconnected during the pre-oxygenation phase.

During the *Patient disconnected* phase, the following alarms are turned off for up to 60 seconds:

- apnea
- minute volume
- respiratory rate
- PEEP

When the patient is reconnected, the system automatically enters the post-oxygenation phase and then resumes ventilation. It is also possible to restart ventilation manually by tapping *START VENTILATION*.

- *Post-oxygenation*

After reconnection, the ventilator system will deliver the same oxygen concentration as in the pre-oxygenation phase for 60 seconds.

After 60 seconds the system automatically returns to ventilation using the previous oxygen concentration setting.

Closed suctioning

When using a closed-suction system, *DISCONNECTION/SUCTION* should not be used. The O₂ boost function should be used instead for oxygenation purposes. Consider pre-silencing the alarms before suctioning.

Use one of the pressure-based modes listed here. Adjust settings to levels suitable for the patient and follow hospital guidelines for closed suctioning.

- PC
- PS
- Bi-Vent/APRV
- SIMV (PC) + PS

6.14 Previous mode

When *MODES* is tapped in the quick menu during operation, the current mode tile is always highlighted and the previous mode tile is marked *PREVIOUS*, together with the date and time it was used.

Note: If the previous mode was non invasive and the current mode is invasive, or vice versa, it is necessary to go to Standby and choose the relevant ventilation type to find the previous mode.

To recall the previous ventilation mode used:

- Tap the tile marked with an arrow in the *MODES* window.
- A dialog will open asking *Do you want to keep the previous settings for the mode?*
- Tap one of the two choices *Yes* or *No* as appropriate.
 - If *Yes* is tapped, the mode settings window will open with the previous settings intact.

Important: If one or several settings in the mode settings window are highlighted in yellow, this indicates that it/they should be considered for adjustment, as the values entered there may have been carried over from the previous mode.

- If *No* is tapped, the mode settings window will open with default settings, which may then be adjusted.

Notes:

- The previous mode function is not available:
 - after a pre-use check
 - after changing the patient category
 - after admitting a new patient
 - after using the same ventilation mode for more than 24 hours
 - after restarting the system.
- When the previous mode function is activated during backup ventilation, the ventilator system returns to the mode that was active before the supported mode was initiated.
- A recall of previous settings is only possible after a change of ventilation mode.

6.15 Apnea management

6.15.1 Apnea time

Apnea time is the time without a patient breathing effort that the ventilator system will allow to elapse in supported ventilation before the *No patient effort* alarm is activated and the ventilator system switches to the backup mode.

The relevant backup mode is highlighted in white in the heading on the screen and the alarm *No patient effort* is displayed.

If the patient triggers a breath, the ventilator system automatically switches back to supported ventilation and the *No patient effort* alarm disappears.

Apnea time is available in all supported modes and in all SIMV modes. Set the apnea time that is appropriate for each patient in the mode settings window.

Note: In SIMV modes, there is no backup ventilation and the apnea time only controls the *No patient effort* alarm. The apnea time is therefore set in the *ALARM LIMITS* window.

Refer to chapter Alarm handling on page 109 and to section Alarm limits on page 145.

6.15.2 Backup ventilation

For invasive modes, backup ventilation entails a switch in case of apnea:

- from VS to PRVC
- from PS/CPAP to PC.

For non invasive modes, the switch is from NIV PS to NIV PC.

When the relevant backup mode is activated while ventilating in a supported mode, the name of the mode is highlighted in white in the mode heading and the backup parameters in the direct access bar are shown as active.

The following parameters are set under the backup mode heading in the mode settings window:

- PC above PEEP (cmH₂O) for PS backup.
The minimum backup pressure level is 5 cmH₂O.
- Tidal volume (ml) for VS backup.
- Respiratory rate (b/min)
- I:E or Ti (s) (depending on configuration)

Refer to section Settings on page 41.

Backup ventilation trends

The number of switches to backup ventilation per minute is trended under *TRENDS & LOGS/TRENDS*.

The percentage time spent in backup ventilation per minute is also trended.

No consistent patient effort

This alarm occurs in invasive ventilation only.

If the patient fulfils the criteria for the *No consistent patient effort* alarm, the ventilator system will lock in backup ventilation.

A dialog *Backup ventilation active - review ventilation settings or continue in supported mode*. is displayed on the screen. A choice must be made or this dialog will remain open and the ventilator system will remain in backup ventilation.

Tap *Review ventilation settings* in the dialog window to return to the mode settings window.

- Tap *Cancel* to close the mode settings window without changes being applied. Ventilation will continue as before, i.e. in backup ventilation.
- Tap *Accept* to accept the settings and continue in the supported mode with a reset apnea time.

Alternatively, tap *Continue in supported mode* in the dialog window to return to the supported mode. The apnea time will be reset.

Refer to chapter Alarm handling on page 109 and to section Alarm limits on page 145.

6.15.3 Deactivating backup ventilation

It is possible to deactivate backup ventilation for invasive PS/CPAP and VS. If backup ventilation is deactivated, the *No patient effort* alarm will be activated at the end of the apnea time but no backup ventilation will start.

To allow deactivation of backup ventilation:

- Tap *SERVICE & SETTINGS* in the extended menu in *STANDBY*.
- Tap *BIOMED* and enter the code, then tap *CONFIGURATION/STARTUP CONFIGURATION/Deactivation of backup function*.
- Change from *Not allowed* to *Allowed*.

If this choice is made, *Deactivate backup ventilation* is displayed at the top right of the mode settings window during ventilation.

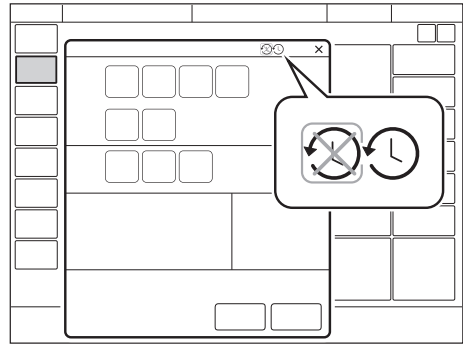

To deactivate backup ventilation:

- Tap *Deactivate backup ventilation* in the mode settings window.
- A confirmation dialog *Do you really want to deactivate backup ventilation?* is displayed. Confirm by pressing *Yes*.
- Tap *Accept* in the mode settings window.
- *Backup ventilation off* is displayed after the mode name in the heading when ventilation then begins.

The backup function is automatically re-activated if:

- a change is made to a controlled mode of ventilation
- the ventilator system is switched to Standby
- the system is turned off.

Note: Backup ventilation remains inactive if a change of mode is made between PS/CPAP and VS.

6.16 Nebulization

6.16.1 Aerogen nebulizers

The nebulizer is intended for administering drugs to patients requiring mechanical ventilation.

The nebulizer operates for a specific period of time or continuously regardless of ventilation mode setting. No extra gas volume is added, i.e. ventilator system settings and values are not affected.

Refer also to the manufacturer's operating manual for instructions for use.

6.16.2 Safety guidelines

WARNINGS!

- The nebulizer must not be left unattended when connected to a patient.
- Before administering any medication via the nebulizer, consult the manufacturer regarding the appropriateness of nebulization for that medication. Only use physician prescribed solutions.
- Do not use the nebulizer without a filter, e.g. Servo Duo Guard, connected to the expiratory inlet of the ventilator system. Refer to the Servo Duo Guard User's Manual.
- During nebulization, carefully monitor the airway pressure. Increased airway pressure could result from a clogged expiratory filter. Replace the filter if the expiratory resistance increases.
- The ventilator system accuracy can be affected by the gas added by use of other nebulizers than Aerogen nebulizer.

- During nebulization, check frequently that aerosol is being generated.
- Disconnect the SERVO Humidifier/HME during nebulization; otherwise the humidifier may become blocked or the drug may be trapped in the humidifier.
- To avoid explosion hazards, do not use flammable agents such as ether and cyclopropane or aerosolize alcohol-based medications which can ignite in oxygen enriched air under high pressure with this device.
- To avoid mechanical or electrical damage, do not drop the nebulizer unit.

CAUTIONS:

- Before starting the nebulizer, check that the medication cup is undamaged and firmly in place.
- If the nebulizer is used with active humidification, then the particle size of the medication may be affected.
- Perform a function test prior to use to verify proper operation.

Important:

- Condensate can collect and occlude ventilator system circuits. Always position ventilator system circuits so that fluid condensate drains away from the patient.
- Do not touch the domed aperture plate in the center of the nebulizer.
- Do not use the Aerogen Pro nebulizer unit in the continuous nebulization.
- Always maintain the nebulizer in a vertical position (with the filler cap uppermost) while in the patient circuit. This position prevents condensate from blocking the nebulizer and ensures proper nebulization.
- When removing the nebulizer unit from the patient circuit, always replace the T piece plug to maintain circuit pressure.
- The nebulizer unit and T piece, as packaged, are not sterile.
- Never use reusable connectors with disposable nebulizer units and vice versa.

Refer to section Nebulizer function test on page 103.

6.16.3 Use guidelines

Assemble nebulizer unit

Important: Use only with components specified by Maquet/Aerogen.

- Perform a function test prior to use to verify proper operation. Refer to section Nebulizer function test on page 103.
- Connect the nebulizer unit to the T piece by pushing the nebulizer unit firmly onto the T piece.

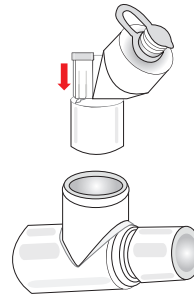

- Insert the nebulizer and the T piece into the inspiratory tube of patient circuit close to the Y piece.
- Connect the control cable to the ventilator system.

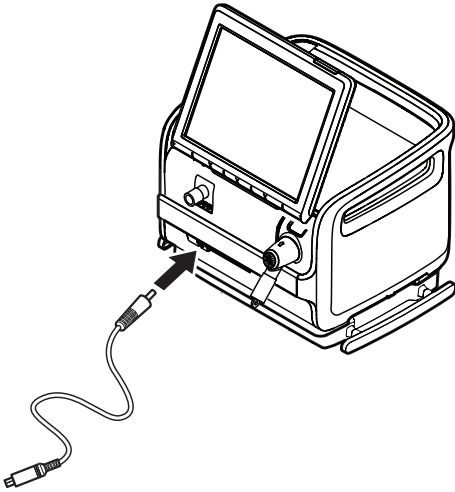

Connection to patient circuits

Connect the nebulizer between the inspiratory tube and the Y piece. Connect the control cable to the ventilator system.

Connecting to 22 mm patient circuits

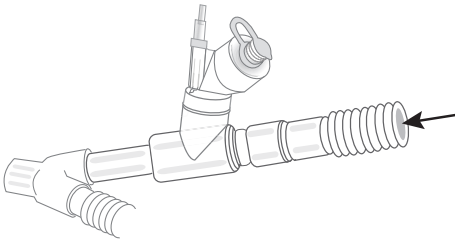

Connecting to 15 mm patient circuits

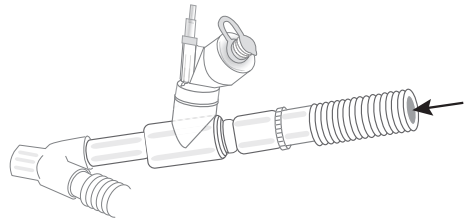

Connecting to 10 mm patient circuits

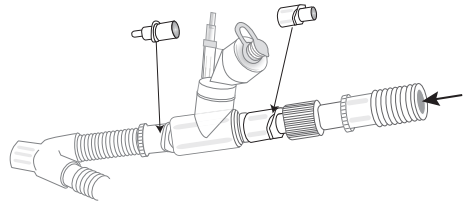

Nebulizer function test

Perform a function test prior to first use or at any time to verify proper operation.

- Visually inspect each part of the system for cracks or damage and replace if any defects are visible.
- Pour 1-6 ml of sterile water or normal saline (0.9 %) into the nebulizer unit.
- Connect the control cable to the ventilator system.
- Start nebulization.
- Check that the aerosol is visible.
- Discard any remaining liquid before patient use.

Adding medication

Note: Do not use a syringe with a needle to add medication.

- Open the filler cap plug on the nebulizer unit.
- Use a pre-filled ampoule or syringe to add medication into the filler port of the nebulizer unit.
- Close the filler cap plug.

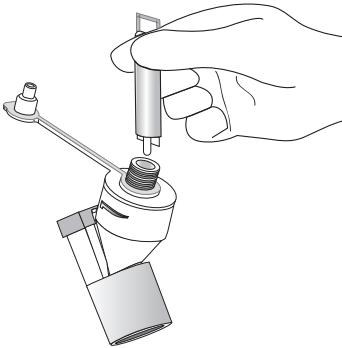

Note: Medication can also be added in this manner during nebulization. This does not interrupt nebulization or ventilation.

Nebulization

Nebulization can be either:

- switched on/off for a certain period of time
- continuous, only Aerogen Solo

Nebulization On/Off

To operate the nebulizer for a specific period of time (on/off):

1. Tap *MANEUVERS/NEBULIZATION*.
2. Tap *Time* if more or less than 10 minutes is required and adjust the figure up or down.

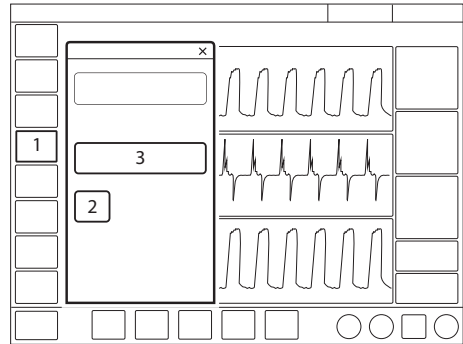

If the nebulizer cable is not connected, a dialog *Check nebulizer cable connection* is displayed on the screen. Tap *OK* to accept.

3. Tap *START NEBULIZATION PERIOD*. The default is 10 minutes.
4. Check that nebulization is in progress and how much time remains by looking at the progress symbol.

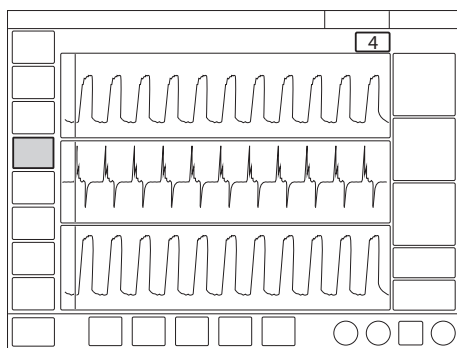

5. To stop nebulization tap *MANEUVERS/NEBULIZATION* or the nebulization shortcut in the status bar.
6. Tap *STOP NEBULIZATION PERIOD*.

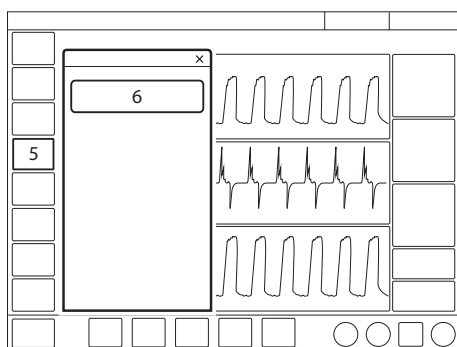

6.16.4 Pro nebulizer unit

Important: The nebulizer unit holds up to 10 ml of liquid medication.

When the nebulizer unit is connected into the inspiratory tube, the filler cap plug can be opened and closed in between doses without causing loss of circuit pressure.

WARNING! Do not attach a continuous supply of medication to the nebulizer; the device operates in 5 to 30 minute cycles.

Note: The nebulization rate is >0.2 ml/min, fill the medication cup and set the nebulization time accordingly.

6.16.5 Solo nebulizer unit

Important: The nebulizer unit holds up to 6 ml of liquid medication.

When the nebulizer unit is connected into the inspiratory tube, the filler cap plug can be opened and closed in between doses without causing loss of circuit pressure.

WARNING! Do not use the Solo nebulizer in conjunction with the administration of volatile anaesthetics as this may have an adverse effect on the Solo nebulizer or T piece plastics.

Important: This is a single patient use device not to be used on more than one patient to prevent cross-infection.

Continuous nebulization

See Aerogen Continuous Nebulization Tube assembly instructions.

CAUTIONS:

- Check regularly the level of medication in the nebulizer unit during continuous nebulization.
- There is no alarm to indicate that the nebulizer is empty.

Important: To ensure correct and safe connection between the nebulizer and the medication reservoir, follow the medication tube from the nebulizer to the medication reservoir to make sure that the medication tube is connected to the correct source.

The input rate of medication into the nebulizer unit during continuous nebulization must not exceed 0.2 ml per minute or 12 ml per hour. Dose volumes and concentrations must be determined accordingly.

To operate the nebulizer in continuous mode:

1. Tap *MANEUVERS/NEBULIZATION*.
2. Tap *START CONTINUOUS NEBULIZATION*.

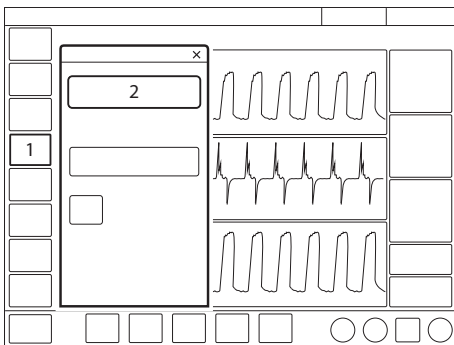

A dialog *Ensure that an Aerogen Solo nebulizer unit is connected* is displayed on the screen. Tap *Accept*.

3. Check that nebulization is in progress by looking at the progress symbol.

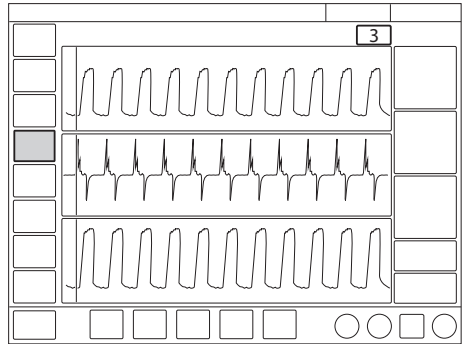

4. To stop nebulization tap *MANEUVERS/NEBULIZATION* or the nebulization shortcut in the status bar.
5. Tap *STOP CONTINUOUS NEBULIZATION*.

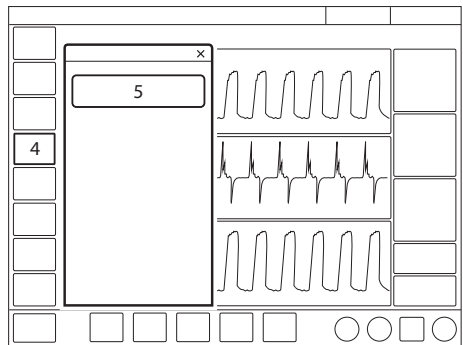

6.17 Adjust the O₂ cell

If the ventilator system has been in continuous use for an extended period, the measured O₂ concentration may drop due to normal degradation of the oxygen cell. In order to avoid nuisance alarms in this situation, it is possible to temporarily adjust the O₂ cell during ventilation.

When performing a O₂ cell adjustment, the O₂ cell is adjusted so that the current measured O₂ concentration is equal to the set O₂ concentration. This temporary adjustment will be valid until the ventilator system is switched off.

Important: Before using the ventilator system, always perform a pre-use check to make sure the O₂ cell is properly calibrated.

To adjust the O₂ cell:

- Tap *CALIBRATION & TESTS* in the extended menu.
- Tap *O₂ CELL ADJUSTMENT* once, then again.
- Tap *Yes* to perform the O₂ cell adjustment.
- Tap *OK*.

7 Alarm handling

Table of contents

7.1	Introduction	110
7.2	Handling alarms	111
7.3	Permanently silencing alarms	114
7.4	Alarms	115
7.5	Alarm output connection (option)	122

7.1 Introduction

7.1.1 General

The ventilator system is equipped with an alarm system to help ensure patient safety. Visual and audible alarms warn about:

- patient breathing problems e.g. apnea
- power problems e.g. loss of mains power
- problems with gases e.g. low supply pressure
- technical problems e.g. hardware failure

WARNING! A potential hazard can arise if different default alarm settings are used on ventilator systems or similar equipment which are located within the same intensive care unit.

CAUTION: Always make sure relevant values are set. Extreme settings may render the alarm system unusable.

Important: Those responding to alarms must be healthcare professionals who have experience in ventilation treatment and who have been trained in the use of this ventilator system.

Note: The alarm log is not affected by system shutdown or a temporary loss of power (supply mains and/or battery power).

Refer to section Set alarm limits on page 42.

7.1.2 Conditions leading to default alarm settings

Alarm limits are set to their default values when:

- powering on the ventilator system
- changing ventilation type (invasive/non invasive)
- changing patient category in *STANDBY*

7.2 Handling alarms

7.2.1 Alarm indication

The alarms are divided into three priorities:

- high priority — all alarm indications are red
- medium priority — all alarm indications are yellow
- low priority — all alarm indications are blue

Technical error messages indicating a technical problem are presented together with a numeric code, TE: x.

When the alarm log is full, the oldest data is discarded when new alarms are added.

An alarm message explaining the cause of the alarm is displayed in the alarm list in the status bar.

The numerical value for the parameter causing the alarm flashes with the color of the alarm priority and the exceeded alarm limit is circled in the same color.

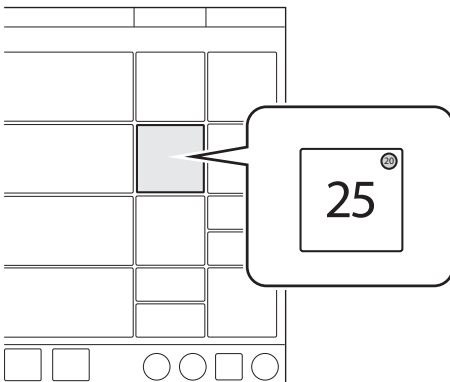

Alarm sound level

When one or more alarms are activated, the system will present the audio signal corresponding to the alarm with the highest priority that is not silenced or turned off.

The alarm volume can be set in the *ALARM LIMITS* window.

Refer to section Set alarm sound level on page 43.

The set alarm sound level is not maintained, when changing between invasive and non invasive ventilation and vice versa.

The default alarm sound level can be set in *SERVICE & SETTINGS/BIOMED/ CONFIGURATION/ALARMS* window.

Refer to section Alarms on page 127.

7.2.2 Viewing active alarms

If more than one alarm is active, open the alarm list in the status bar.

All alarms are displayed by priority in the alarm list. The list will be continuously updated when additional alarms occur.

Each alarm is displayed together with a list of recommended actions.

Tap *Alarm history* in the alarm list to open the *ALARM HISTORY* window.

7.2.3 Responding to alarms

Active alarms can be silenced for two minutes by tapping *Audio pause* in the status bar.

Audio paused along with the time remaining in the silent period are displayed.

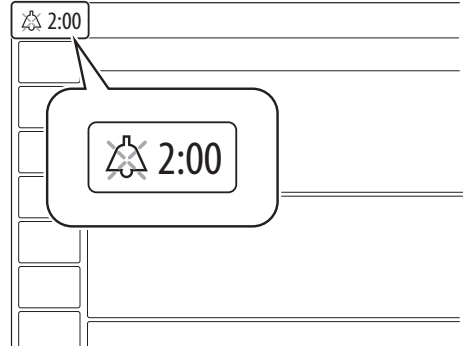

Audio pause must be tapped for each alarm that is activated.

If *Audio Paused* is tapped before the silent period has expired, then the alarm signal will be turned on again if the alarm is still active.

Note: The *No battery capacity* alarm and high priority technical alarms cannot be silenced.

To respond to alarms:

- Tap *Audio pause* to silence the alarm for two minutes.
- Take action to resolve the alarm condition.

Low and medium priority alarms are automatically reset once the alarm condition ceases.

High priority alarms are reset automatically or by confirmation of the alarm.

Refer to section *Resetting Check alarms* on page 113.

7.2.4 Pre-silencing alarms

To silence most alarms for two minutes, tap *Audio pause* when no alarms are active. A crossed double bell, *Audio pause - all alarms*, along with the time remaining in the silent period are displayed.

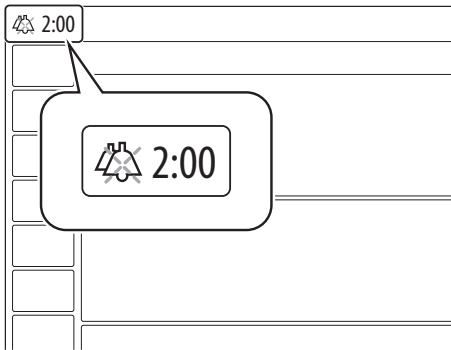

7.2.5 Responding to technical alarms

In some cases, restarting the system may resolve a technical alarm. However, technical alarms often necessitate taking the ventilator system out of operation and having it serviced.

Refer to section Technical error alarms on page 120.

7.2.6 Resetting Check alarms

Check alarms is an indication of high priority alarms that have ceased. The alarm indication remains visible in the status bar and in the alarm list until the *ALARM HISTORY* window is opened.

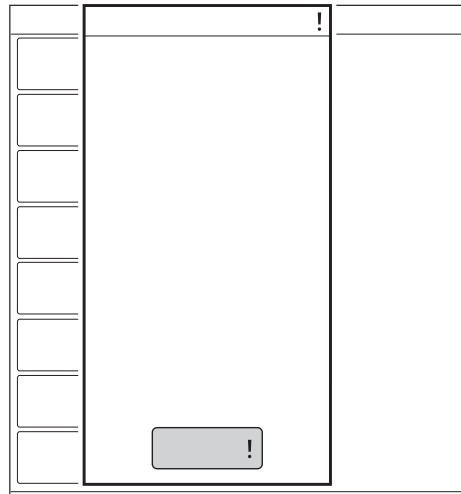

To reset *Check alarms*:

Tap *Alarm history !* in the alarm list.

The *ALARM HISTORY* window opens and the *Check alarms* is reset. The indication is cleared from the screen.

7.3 Permanently silencing alarms

Certain alarms can be permanently silenced in the *ALARM LIMITS* window.

In non invasive ventilation:

- respiratory rate
- end expiratory pressure

WARNING! Always ensure adequate external patient monitoring (e.g. SpO₂, CO₂) in invasive ventilation when the *Expiratory minute volume low* alarm is set to *Audio off*.

To permanently silence alarms:

- Tap *ALARM LIMITS* in the extended menu.
- Tap *Audio pause* below the alarm limit setting and select *Audio off*.
- Tap *Accept*.

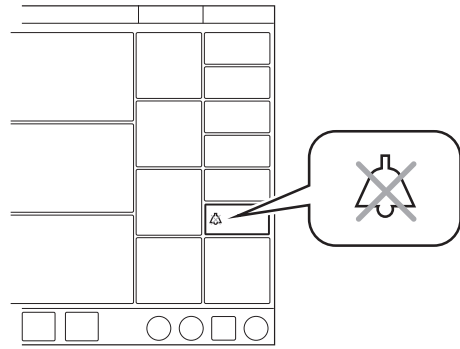

Audio off is displayed in the corresponding parameter in the numerical values area and a message is displayed in the status bar.

A message indicating the number of permanently silenced alarms is also displayed in the status bar. Tap to display the list.

Note: The default alarm settings are automatically set when switching between invasive and non invasive modes.

The alarms can be set to permanently silenced as default in *SERVICE & SETTINGS/BIOMED/CONFIGURATION/ALARMS* window.

Refer to section Alarms on page 127.

7.4 Alarms

7.4.1 High priority alarms

Alarm message	Possible causes	Alarm management checklist
Airway pressure high	<p>Airway pressure exceeds preset upper pressure limit.</p> <p>Kinked or blocked tubing.</p> <p>Mucus or secretion plug in endotracheal tube or in airways.</p> <p>Patient coughing or fighting ventilator.</p> <p>Inspiratory flow rate too high.</p> <p>Improper alarm setting.</p> <p>Blocked expiratory filter.</p>	<p>Check patient circuit.</p> <p>Check expiratory filter.</p> <p>Check ventilator settings.</p> <p>Check alarm limits.</p>
Apnea	<p>Time between two consecutive inspiratory efforts exceeds the set alarm limit.</p>	<p>Check patient.</p> <p>Check ventilator settings.</p>
Patient circuit disconnected	<p>Patient circuit disconnected</p> <p>Problems with patient circuit or expiratory pressure transducer.</p> <p>Disconnected pressure transducer (expiratory or inspiratory).</p> <p>Blocked pressure transducer (expiratory or inspiratory).</p> <p>Water in expiratory limb of ventilator.</p> <p>Wet or clogged expiratory filter.</p> <p>Excessive leakage.</p>	<p>Check patient circuit.</p>
Time in waiting position > 2 min	<p>Time in waiting position is exceeded.</p> <p>Patient is not connected to the ventilator or leakage is excessive.</p>	<p>Connect patient.</p> <p>Check patient circuit.</p>
Leakage too high	<p>Leakage too high. The mask/prongs may not be adjusted properly for the patient or may be the wrong size.</p>	<p>Check patient interface.</p> <p>Check patient circuit.</p>
Gas supply pressures low	<p>O₂ supply is below 2.0 kPa x 100 (29 psi).</p> <p>O₂ gas supply disconnected.</p>	<p>Check gas supply.</p>
Expiratory minute volume low	<p>Preset or default alarm limit exceeded.</p> <p>Low spontaneous patient breathing activity.</p> <p>Leakage around the cuff.</p> <p>Leakage in the patient circuit.</p> <p>Improper alarm setting.</p> <p>Note: This alarm also works as a patient disconnect alarm.</p>	<p>Check patient.</p> <p>Check patient circuit.</p> <p>Check ventilator settings.</p> <p>Check support level.</p>
Low battery voltage	<p>Battery voltage too low. Cannot guarantee continued ventilator system operation.</p>	<p>Connect to mains power.</p> <p>Replace all batteries.</p>

Alarm message	Possible causes	Alarm management checklist
Airway pressure continuously high	Obstruction leading to constant high airway pressure (>PEEP +15 cmH ₂ O) during: <ul style="list-style-type: none"> > 2 breaths or 5 seconds, whichever is greater, 15 ±1.5 s if less than 2 breaths are triggered) 	Check patient circuit. Check ventilator settings. Check alarm limits. Contact service technician.
O ₂ concentration low	Gas delivered in O ₂ supply line is not O ₂ . O ₂ cell uncalibrated. Gas module for O ₂ faulty.	Check O ₂ supply. If using an O ₂ cell, perform O ₂ cell adjustment. Perform a pre-use check.
Patient disconnected > 1 min	Patient circuit disconnected.	Reconnect patient. Check patient circuit.
Alarm limits invalid	Alarm limits lost.	Replace the ventilator immediately.
No battery capacity (with two batteries)	Less than 3 minutes left of battery operation.	Connect to mains power to charge battery. Replace the battery in slot 1.
No battery capacity (with one battery)	Less than 3 minutes left of battery operation.	Connect to mains power to charge battery. Insert an additional battery in the empty slot.

7.4.2 Medium priority alarms

Alarm message	Possible causes	Alarm management checklist
Expiratory cassette disconnected	The expiratory cassette is disconnected or not connected properly.	Check that the expiratory cassette is properly inserted.
Limited battery capacity (with two batteries)	Less than 10 minutes left of battery operating time.	Connect to mains power to charge battery. Replace battery in slot 1.
Limited battery capacity (with one battery)	Less than 10 minutes left of battery operating time.	Connect to mains power to charge battery. Insert an additional battery in the empty slot.
O ₂ supply pressure low	O ₂ supply pressure below 2.0 kPa x 100 (29 psi). O ₂ supply pressure at gas inlet is too low. Gas supply line disconnected. Note: This alarm can be permanently silenced (<i>Audio off</i>) when activated.	Check O ₂ supply.
PEEP high	The measured end expiratory pressure is above the preset or default alarm limit for three consecutive breaths.	Check patient circuit. Check alarm settings. Check ventilator settings.
PEEP low	The measured end expiratory pressure is below the preset or default alarm limit for three consecutive breaths. Setting the alarm to zero turns the alarm off. Leakage in patient circuit. Leakage at patient connection (cuff, tracheal tube).	Check patient circuit. Check alarm settings. Check ventilator settings.
O ₂ concentration high	<ul style="list-style-type: none"> Flow meters poorly calibrated. Technical problems 	Perform a pre-use check.
O ₂ supply pressure high	O ₂ supply pressure above 6.0 kPa x 100 (87 psi). O ₂ supply pressure at gas inlet is too high.	Check O ₂ supply.
Pressure delivery restricted	The inspiratory flow has reached its upper limit, which restricts pressure delivery.	The inspiratory flow has reached its upper limit, which restricts pressure delivery. Check for leakage. Check ventilator settings.
Respiratory rate high	Respiratory rate too high. Autotriggering.	Check patient. Check ventilator settings. Check patient circuit.

Alarm message	Possible causes	Alarm management checklist
Respiratory rate low	Respiratory rate too low. Trigger setting incorrect. Large tidal volume.	Check patient. Check ventilator settings. Check patient circuit.
Expiratory minute volume high	Increased patient ventilation activity. Ventilator autotriggering. Improper alarm limit setting.	Check patient. Check ventilator settings. Check patient circuit.
Leakage too high	Leakage too high. The mask/prongs may not be adjusted properly for the patient or may be the wrong size.	In invasive ventilation: Check patient circuit. Check endotracheal tube. In non invasive ventilation: Check patient circuit. Check patient interface.
Expiratory cassette error	Technical problem with the expiratory cassette.	Replace the expiratory cassette. Perform a pre-use check. Contact service technician.
Nebulizer disconnected	The nebulizer is disconnected during nebulization. Technical problem with connection cable.	Check nebulizer connection.
No patient effort	An apnea has caused the ventilator to switch to backup ventilation.	Check patient. Check ventilator settings.
No consistent patient effort	The ventilator has switched between supported and backup ventilation four times in two minutes. The patient has only triggered a single breath to interrupt each of two consecutive backup periods.	—
Internal temperature too high	Temperature inside the ventilator is too high.	Replace the ventilator as soon as possible.
Blocked air inlet	Possible occlusion of air inlet filter Replacement of dust filter necessary Replacement of air inlet filter is necessary due to occlusion	Check that the air inlet filter is not occluded. Check the dust filter and replace it if necessary. Replace the air inlet filter if the problem remains.
Delivered gas temperature high	Temperature exceeds 43 °C.	Check air inlet for obstructions. Decrease ambient temperature.
No battery backup	No battery is installed.	No battery is installed. At least one battery in slot 2 is required.
Nebulizer hardware error	Technical problem with nebulizer hardware. Technical problem with connection cable.	Contact service technician.

7.4.3 Low priority alarms

Alarm message	Possible causes	Alarm management checklist
Battery operation	The mains power is interrupted.	Check mains power connection.
Volume delivery is restricted	The pressure is limited to 5 cmH ₂ O below the set upper pressure limit, which restricts the volume delivery.	Check ventilator settings. Check alarm limits.
Expiratory cassette replaced	The expiratory cassette has been replaced during operation. A pre-use check is not performed after the replacement.	Perform a pre-use check.
Turbine temperature high	Air inlet filter is obstructed. Ambient temperature is too high. Ventilator settings are outside normal ranges. Technical failure in turbine.	Check air inlet filter and patient circuit. Check ambient temperature close to air inlet. Check ventilator settings.
No slot 2 battery capacity	Less than 3 minutes left of battery operation in battery in slot 2	Connect to mains power to charge battery. Replace the battery in slot 2.

7.4.4 Technical error alarms

Note: Most technical problems require the attention of service personnel.

High priority alarms

Error code number	Possible causes	Alarm management checklist
1 - 6, 75 - 82	Internal power failure.	Replace the ventilator immediately.
10, 11	Control system error.	Replace the ventilator immediately.
37, 40001-40011	Expiratory flowmeter error.	Replace the ventilator immediately.
7, 60	Internal error.	Replace the ventilator immediately.
42, 44, 10003	Internal memory error.	Replace the ventilator immediately.
16, 25, 35, 43, 55	Internal communication error.	Replace the ventilator immediately.
8, 9	Timeout error.	Replace the ventilator immediately.
38, 39	Barometric error	Replace the ventilator immediately.
40	Monitored value not within range.	Replace the ventilator immediately.
62	Very high turbine temperature	Replace the ventilator immediately.
7	Inspiratory valve error	Replace the ventilator immediately.
74	Inspiratory flow meter error	Replace the ventilator immediately.
63, 83	Turbine communication error	Replace the ventilator immediately.
64 - 69	Turbine failure	Replace the ventilator immediately.

Medium priority alarms

Error code number	Possible causes	Alarm management checklist
51	On/Off switch error.	Replace the ventilator as soon as it is safe for the patient.
28, 20004	Panel audible alarm error.	Replace the ventilator as soon as it is safe for the patient.
22, 24, 27	Backup audible alarm error.	Replace the ventilator as soon as it is safe for the patient.
40	Monitored value not within range.	Replace the ventilator as soon as it is safe for the patient.
20002	Backlight error.	Replace the ventilator as soon as it is safe for the patient.
71	Ambient air temperature RH % sensor error	Replace the ventilator as soon as it is safe for the patient.
72	Inspiratory gas temperature sensor error	Replace the ventilator as soon as it is safe for the patient.
84	O ₂ evac fan failure	Replace the ventilator as soon as it is safe for the patient.
O ₂ cell failure - TE: x	O ₂ cell missing or disconnected.	Replace the ventilator as soon as it is safe for the patient.
Internal nebulizer error - TE: x	Technical problem with nebulizer hardware. Technical problem with connection cable.	Contact service technician.

Low priority alarms

Error code number	Possible causes	Alarm management checklist
48	Control system error.	Replace the ventilator when convenient.
41	Internal clock error.	Replace the ventilator when convenient.
29	Memory backup battery depleted.	Replace the ventilator when convenient.
56 - 58	Internal memory error.	Replace the ventilator when convenient.
61	Internal error.	Replace the ventilator when convenient.
10004	Internal communication error.	Replace the ventilator when convenient.
46	Remote alarm internal error	Remote alarm inactive. Replace the ventilator when convenient.

After replacing the ventilator system, contact a service technician

7.5 Alarm output connection (option)

The ventilator system is equipped with the alarm output connection, alarms can be transferred to an external signalling system. The alarm output signal is active as long as the alarm audio is active on the ventilator system.

WARNING! Never leave the patient unattended. The external alarm is designed to alert those already in attendance.

CAUTION: Maquet cannot guarantee a distributed alarm system, according to IEC 60601-1-8, where the alarm output is a component. It is recommended that users establish a procedure to check this application before use.

8 Service & Settings

Table of contents

8.1	Introduction	124
8.2	Biomed	124
8.3	Service	128
8.4	Remote Services	129
8.5	License	129

8.1 Introduction

To access *SERVICE & SETTINGS*:

- Tap *SERVICE & SETTINGS* in the extended menu.

Note: The ventilator system must be in Standby.

The following choices are available:

- *BIOMED*
- *SERVICE*
- *REMOTE SERVICES*
- *LICENSE*
- *EXIT*

8.2 Biomed

BIOMED is used for viewing and editing the ventilator settings. The logs can also be managed.

Available options depend on the installed configuration.

To access *BIOMED*:

- Tap *BIOMED*.
- Enter the access code (the factory setting is 1973) and tap Accept.

The following choices are available:

- *STATUS*
- *LOGS*
- *SERVICE REPORT*
- *CONFIGURATION*
- *COPY CONFIGURATION*
- *EXIT*

8.2.1 Status

STATUS is used for viewing system information and installed software options.

To access *System Info.* and *Options*:

- Tap *BIOMED/STATUS*

The following information is available for *System Info.*:

- *O₂ CELL*
- *EXPIRATORY CASSETTE*
- *BATTERY STATUS*

The following information is available for *Options*:

- *INSTALLED OPTIONS*

8.2.2 Logs

LOGS is used for viewing event logs for a certain period of time. A date interval can also be set and a search function is available.

To access *LOGS*:

- Tap *BIOMED/LOGS*.

The following search filters are available:

- *Alarms*
- *Functions*
- *Settings*
- *Configuration*

8.2.3 Service report

SERVICE REPORT is used for reporting service tasks.

8.2.4 Configuration

CONFIGURATION is used for viewing and editing the startup configuration settings and alarms as well as for setting date and time and the biomed code.

To access *CONFIGURATION*:

- Tap *BIOMED/CONFIGURATION*.

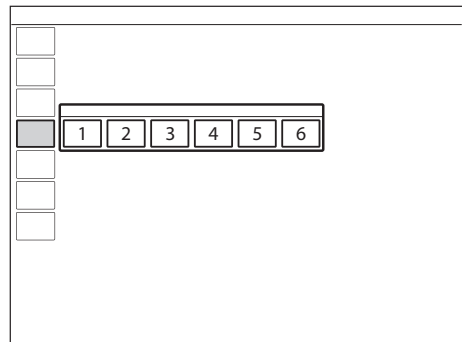

The following configurations can be viewed and edited:

1. *SETTINGS*
2. *STARTUP CONFIGURATION*
3. *ALARMS*
4. *NETWORK*
5. *SET DATE & TIME*
6. *BIOMED CODE*

Settings

SETTINGS is used for configuring the settings for exporting information via Remote Services.

To access *SETTINGS*:

- Tap *BIOMED/CONFIGURATION/SETTINGS*.

Startup Configuration

To access STARTUP CONFIGURATION:

- Tap *BIOMED/CONFIGURATION/STARTUP CONFIGURATION*.

The following items can be viewed and edited:

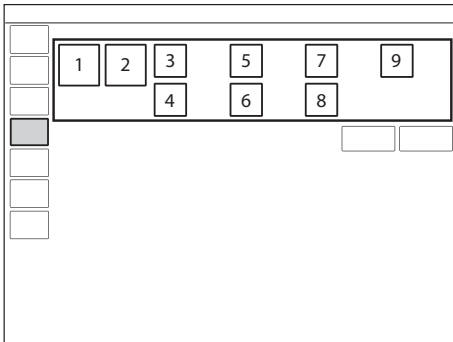

1. Patient category
2. Ventilation type (invasive or non invasive (NIV))
3. Volume setting (Tidal volume, Minute volume)
4. NIV disconnection functionality (Low flow, Disabled or High flow)
5. Breath cycle setting (I:E, Ti)
6. Extended leakage test (Off, On)
7. Temporary O₂ increase (%)
8. Use 0 (s) as default pause time (Off, On)
9. Deactivation of backup function (Not allowed, Allowed)

Edit NIV disconnection function

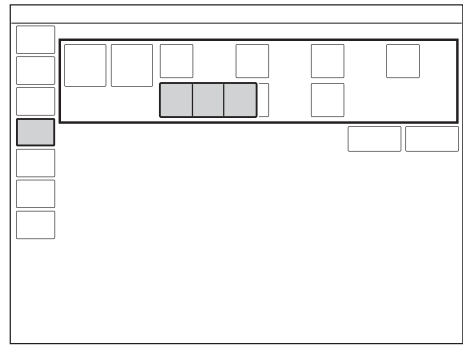

To edit the *NIV disconnection functionality*:

- Tap *CONFIGURATION/STARTUP CONFIGURATION/NIV disconnection functionality*.
- Choose *Low flow, Disabled* or *High flow*.

Refer to section Functions in ventilation modes on page 146.

Edit Temporary O₂ increase (%)

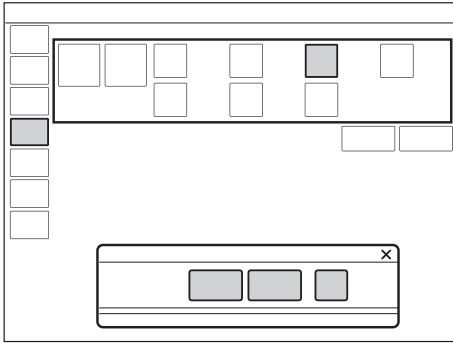

To edit the oxygenation concentration:

- Tap *CONFIGURATION/STARTUP CONFIGURATION/O₂%* and adjust.

The setting entered in the window that opens determines the default setting for the O₂ BOOST LEVEL and the oxygen level increase during pre- and post-oxygenation when DISCONNECTION/SUCTION is used.

It does not affect the O₂ BOOST LEVEL function in the adult patient category where the default is 100 %.

Important: The ventilator system must be restarted to activate the new settings.

Alarms

The alarm settings are the default settings that the ventilator system is delivered with. These defaults can be changed.

To access *ALARMS*:

- Tap *BIOMED/CONFIGURATION/ALARMS*.

The following alarm categories can be viewed and managed depending on the installed configuration:

1. Pediatric
2. Pediatric NIV
3. Adult
4. Adult NIV

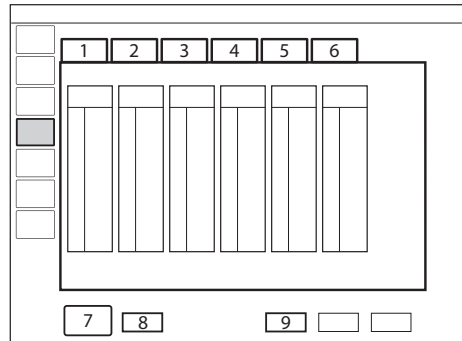

The following can be adjusted:

7. Default audio level
8. Restore default audio level
9. Restore default alarm limits

Options to restore defaults, cancel or save changes are available for all alarms.

Network

NETWORK is used to configure the settings for connecting to Remote Services.

To access *NETWORK*:

- Tap *BIOMED/CONFIGURATION/NETWORK*.

Set date & time

Options to change the date and time are available.

To access *SET DATE & TIME*:

- Tap *BIOMED/CONFIGURATION/DATE & TIME*.

Biomed Code

The current access code is displayed with an option to enter and save a new access code.

To access *BIOMED CODE*:

- Tap *BIOMED/CONFIGURATION/BIOMED CODE*.

8.2.5 Copy configuration

The configuration settings can be copied from or to a USB memory stick.

To access *COPY CONFIGURATION*:

- Tap *BIOMED/COPY CONFIGURATION*.

Note: When the copy is complete, a message will be displayed on the screen.

8.3 Service

The Service menu should only be accessed by a trained service technician that has been certified by Maquet.

8.4 Remote Services

When in *STANDBY*, connect the network cable between the ventilator system and the network.

CAUTION: When using the MCare Remote Services function, instal the network cable so that there is no risk of anyone tripping over it.

To access *REMOTE SERVICES* :

- Tap *SERVICE & SETTINGS/REMOTE SERVICES* in the extended menu.

The following message appears:

- *Running*

When the transfer is complete, the following message appears:

- *Completed*
- Tap *OK*.

Note: The ventilator system is prepared for the MCare Remote Services functionality, although additional equipment is needed to use this function. Please contact the sales and service representative for more details.

8.5 License

LICENSE is used for viewing the list of software components, versions and licensing conditions.

9 Technical data

Table of contents

9.1	System	132
9.2	Ventilator system	134
9.3	Standard condition specification	135
9.4	Essential performance	136
9.5	Patient circuit	136
9.6	Inspiratory channel	137
9.7	Expiratory channel	138
9.8	Monitoring	139
9.9	Ventilatory settings	142
9.10	Alarms	145
9.11	Functions in ventilation modes	146
9.12	Trends	147
9.13	Logs	148
9.14	Service	149
9.15	Aerogen nebulizer	150
9.16	Communication/interface	152
9.17	Accessories	153
9.18	Health and Environment	155
9.19	UDI label	156
9.20	Technical description	157

9.1 System

General	
Standards	<ul style="list-style-type: none"> • IEC 60601-1: 2005 + A1:2012, Class I, continuous operation Applied parts <ul style="list-style-type: none"> - Equipment making physical contact with the patient and the gas path ways. Type B - Nebulizer patient unit and cable. Type BF <p>Applied parts, i.e. equipment making physical contact with the patient, are described in <i>System Flow Chart, SERVO-air</i>.</p> <ul style="list-style-type: none"> • ISO 80601-2-12:2011 • ISO 80601-2-55:2011 • EN 13544-1:2007 + A1:2009
Electromagnetic compatibility (EMC)	<p>According to IEC 60601-1-2:2007</p> <p>The EMC declaration: <i>Information to the Responsible Organization</i> is available from Maquet.</p>
Patient category	<p>Tidal volume</p> <ul style="list-style-type: none"> • Pediatric: 20 - 350 ml • Adult: 100 - 2000 ml
Ingress protection	<p>IP 21</p> <p>The IP 21 classification implies that the enclosure is protected against solid foreign objects represented by a test finger with a diameter of 12 mm pressed with a force of 10 N, and a sphere with a diameter of 12.5 mm pressed with a force of 30 N against all openings in the enclosure, as well as dripping water with a flow rate of 1 mm/min for ten minutes.</p>
Noise	<ul style="list-style-type: none"> • A-weighted sound pressure level (L_{pA}): <49 dB, measured at a distance of 1 m • A-weighted sound power level (L_{WA}): <57 dB
Information signal	<p>Single beep</p>

Operating Conditions	
Operating temperature range	5 to 40°C
Relative humidity	5 to 95 % non-condensing
Atmospheric pressure	660 to 1060 hPa
Lowest pressure in patient circuit	-400 cmH ₂ O
Non operating conditions	
Storage temperature	-25 to +60° C (-13 to 140° F)
Storage relative humidity	< 95 % condensing
Storage atmospheric pressure	470 to 1060 hPa
Power supply	
Power supply, automatic range selection	Rated input power <ul style="list-style-type: none"> • 100 - 240V AC ±10 % Auto range <ul style="list-style-type: none"> • 50 - 60 Hz
Typical mean power consumption, range	30 - 100 W
Battery backup	<ul style="list-style-type: none"> • 1 - 2 battery modules rechargeable 14.4 V, 6.6 Ah each • Battery backup time factory new battery 2 h fully charged. • Typical recharge time approximately 2 h/battery (90 %), up to 3 h (100 %) if battery is completely discharged Usable backup time depends on set mode and selected ventilation settings. When the ventilator system is in storage, keep the ventilator system connected to mains power to maintain full charge in the batteries.
External 12 V DC	12.0 V – 15.0 V DC, 15 A Fuse: 15 A/32 V Miniblade CAUTION: At least one battery module must always be installed. Information regarding connector wiring is available from Maquet.
Battery disposal	Do not dispose of battery modules and O ₂ cells with ordinary waste.
Battery lifetime	4 years from manufacturing date or 300 charge cycles which ever comes first.

9.2 Ventilator system

General

Dimensions	<ul style="list-style-type: none"> • User interface: W 300 x D 34 x H 248 mm • Patient unit: W 375 x D 350 x H 275 mm
------------	---

Weight, approximate	Approx. weight: 15 kg
---------------------	-----------------------

Gas supply

Ambient air	Dust and HEPA filtered ambient air.
-------------	-------------------------------------

Gas quality, O ₂	Supplied gas must meet the requirements for medical grade gases according to applicable standards.
-----------------------------	--

Maximum level, O ₂	<ul style="list-style-type: none"> • H₂O < 20 mg/m³ • Oil < 0.3 mg/m³
-------------------------------	--

Inlet gas, O ₂	<ul style="list-style-type: none"> • Pressure: 2.0 – 6.0 kPa x 100 (29 – 87 psi) • Maximum continuous flow 60 l/min
---------------------------	---

Connection standards available	AGA, DISS, NIST, or French
--------------------------------	----------------------------

Patient system connectors

Conical fittings	Nominal 22 mm and 15 mm, in accordance with ISO 5356-1
------------------	--

Pressure line connector	Gable mounted bulk head connector to fit tubings with an inner diameter of 3-4 mm
-------------------------	---

Gas exhaust port	Male 30 mm cone
------------------	-----------------

9.3 Standard condition specification

Inaccuracy ranges in this document assume the following standard conditions, normal use and the worst case, i.e. all errors are summarized positive.

Standard condition specification	
Ambient pressure	101.3 kPa
Room temperature	21°C
Inlet pressure	4.3 kPa x 100
Pre-use check	<ul style="list-style-type: none"> • Pre-use check performed on a warmed up ventilator system • Pre-use check performed with ≥ 99 % oxygen content in O₂ supply
Circuit compensation	Circuit compensation is activated.
Settings	Default settings unless otherwise specified
I:E	Set I:E is less than 1:1.
Ventilatory frequency	Set ventilatory frequency is less than or equal to 100 breaths/minute.
Leakage	Constant leakage below 30 % in NIV modes.
BTPS	<p>All measured, preset and indicated flows and volumes are referenced to BTPS.</p> <p>Body Temperature and Pressure Saturated. All measured, preset and indicated flows and volumes at +37°C, local atmospheric pressure and relative humidity 100 % (saturated).</p>
STPD	<p>All measured inlet gas pressures and flows are referenced to STPD.</p> <p>Standard Temperature and Pressure Dry. All measured, inlet gas pressures and flows at +20 °C (standard temperature), standard pressure 101.3 kPa and relative humidity 0 % (dry).</p>

9.4 Essential performance

The essential performance for the ventilator system and its options are the delivery of ventilation at the patient connection port within the alarm limits set by the user or generation of an alarm condition.

Essential performance according to IEC 60601-1

Essential performance	<ul style="list-style-type: none"> • Oxygen level alarm conditions • Airway pressure • Expired volume • Electrical supply failure • Internal electrical power source near depletion • Gas supply failure • Gas temperature
-----------------------	---

9.5 Patient circuit

Patient circuit configurations

Range of inspired tidal volumes	<ul style="list-style-type: none"> • Pediatric: 10 - 12 mm tubing, tidal volumes 20 - 100 ml • Pediatric: 15 mm tubing, tidal volumes 20 - 350 ml • Adult: 22 mm tubing, tidal volumes 100 - 2000 ml
---------------------------------	---

Refer to *System Flow Chart, Ventilation, SERVO-air* for information regarding patient circuit configurations to be used with the ventilator system.

9.5.1 Patient circuit test

In the pre-use check, the patient circuit is tested to determine if it is within these recommended ranges. If the tested parameters are within the specified ranges, the inaccuracies stated are maintained.

Patient circuit test

Inspiratory resistance	<ul style="list-style-type: none"> • Pediatric: 0 - 31.0 cmH₂O/l/s at flow rate 10 l/min • Adult: 0 - 7.7 cmH₂O/l/s at flow rate 60 l/min
Expiratory resistance	<ul style="list-style-type: none"> • Pediatric: 0 - 27.0 cmH₂O/l/s at flow rate 10 l/min • Adult: 0 - 5.0 cmH₂O/l/s at flow rate 60 l/min
Compliance	<ul style="list-style-type: none"> • Pediatric: 0.2 - 1.4 ml/cmH₂O at airway pressure 50 cmH₂O • Adult: 0.7 - 2.4 ml/cmH₂O at airway pressure 50 cmH₂O

9.6 Inspiratory channel

Inspiratory channel	
Gas delivery system	Air turbine and O ₂ valve
Gas delivery device	Flow range: <ul style="list-style-type: none"> • Pediatric: 0 - 80 l/min • Adult: 0 - 240 l/min Inaccuracy: $\pm(6 \text{ ml/min} + 5 \% \text{ of set value})$ Maximum pressure setting: <ul style="list-style-type: none"> • Pediatric: 80 cmH₂O • Adult: 100 cmH₂O Inaccuracy: $\pm(1 \text{ cmH}_2\text{O} + 7 \% \text{ of set value})$ ¹
Maximum airway pressure	100 cmH ₂ O
NIV max. leakage compensation level	<ul style="list-style-type: none"> • Pediatric: Inspiratory leakage up to max inspiratory flow. Expiratory leakage up to 25 l/min. • Adult: Inspiratory leakage up to max inspiratory flow. Expiratory leakage up to 65 l/min.
O ₂ concentration	<ul style="list-style-type: none"> • Setting range: 21 - 100 % Inaccuracy: $\pm(5 \% + 5 \% \text{ of set value})$ ²
Inspiratory tidal volume	Air/O ₂ Setting range: <ul style="list-style-type: none"> • Pediatric: 20 - 350 ml • Adult: 100 - 2000 ml Inaccuracy ³ : $\pm(6 \text{ ml} + 10 \% \text{ of set volume})$ ⁴
Inspiratory minute volume	Air/O ₂ Setting range: <ul style="list-style-type: none"> • Pediatric: 0.3 - 20 l/min • Adult: 0.5 - 60 l/min
Maximum inaccuracy of PEEP	<ul style="list-style-type: none"> • Pediatric: $\pm(1 \text{ cmH}_2\text{O} + 5 \% \text{ of set value})$ for $50 \text{ ml} \leq VT \leq 300 \text{ ml}$ • Adult: $\pm(1 \text{ cmH}_2\text{O} + 5 \% \text{ of set value})$ for $VT \geq 300 \text{ ml}$
O ₂ concentration response time from 21 % to 90 % ⁵	<ul style="list-style-type: none"> • Patient category and breathing circuit configuration for $VT \geq 300 \text{ ml}$: Max 30 s • Patient category and breathing circuit configuration for $50 \text{ ml} \leq VT \leq 300 \text{ ml}$: Max 35 s • Patient category and breathing circuit configuration for $VT \leq 30 \text{ ml}$: Max 55 s
Maximum delivered gas temperature	43°C

1. Characteristics valid at conditions specified in ISO 80601-2-12, table 201.104.

2. At high altitudes when using VC with low volumes, O₂ delivery may be higher than the set value.

3. Characteristics valid at conditions specified in ISO 80601-2-12, table 201.103.

4. At high altitudes, when using VC with low volumes, tidal volumes may be lower than the set value.

5. Characteristics valid at conditions specified in ISO 80601-2-12, table 201.105.

9.7 Expiratory channel

Expiratory channel	
Pressure drop	Maximum: 3 cmH ₂ O at a flow of 60 l/min
Internal compressible factor	Maximum: 0.1 ml/cmH ₂ O
PEEP regulation	Microprocessor controlled valve
PEEP setting range	<ul style="list-style-type: none"> • 1 - 50 cmH₂O <li style="padding-left: 20px;">Inaccuracy: $\pm(1 \text{ cmH}_2\text{O} + 5 \% \text{ of set value})$⁶
Expiratory flow measurements	<ul style="list-style-type: none"> • 0 - 192 l/min • Rise time (flow of 3 - 192 l/min): <12 ms for 10 - 90 % response
Bias flow during expiration	2 l/min \pm 5 %

6. PEEP accuracy may decrease for RR \geq 60 b/min together with VT \leq 20 ml.

9.8 Monitoring

Monitoring	
Inspiratory tidal volume	Air/O ₂ Range/Inaccuracy: <ul style="list-style-type: none"> • Pediatric: $\pm(2.5 \text{ ml} + 10 \% \text{ of actual volume})$ for VT 20 ml - 350 ml⁷ • Adult: $\pm(4 \text{ ml} + 7 \% \text{ of actual volume})$ for VT 100 ml - 2000 ml
Expiratory tidal volume	Air/O ₂ Range/Inaccuracy: <ul style="list-style-type: none"> • Pediatric: $\pm(3 \text{ ml} + 10 \% \text{ of actual volume})$ for VT 20 ml - 350 ml⁸ • Adult: $\pm(8 \text{ ml} + 10 \% \text{ of actual volume})$ for VT 100 ml - 2000 ml
Expiratory minute volume	Air/O ₂ Range: <ul style="list-style-type: none"> • Pediatric: 0.3 - 20 l/min • Adult: 0.5 - 60 l/min Inaccuracy: <ul style="list-style-type: none"> • Pediatric: $\pm(0.2 \text{ l/min} + 9 \% \text{ of actual value})$⁹ • Adult: $\pm(0.15 \text{ l/min} + 8 \% \text{ of actual value})$¹⁰ Inaccuracy, NIV: <ul style="list-style-type: none"> • Pediatric: $\pm(0.2 \text{ l/min} + 10 \% \text{ of actual value})$¹¹ • Adult: $\pm(0.15 \text{ l/min} + 10 \% \text{ of actual value})$¹²
Respiratory rate	<ul style="list-style-type: none"> • Range: 1 - 160 b/min Respiratory rate must be measured with a maximum inaccuracy of ± 1 b/min.
O ₂ concentration	<ul style="list-style-type: none"> • Range: 0 – 100 % Inaccuracy: $\pm(2.5 \text{ vol}\% + 2.5 \% \text{ of actual gas concentration})$ <ul style="list-style-type: none"> • Stability (within 8-hour period): $\pm(2.5 \% \text{ volume} + 2.5 \% \text{ of actual gas concentration})$ The inaccuracy of the measurement is dependent on the oxygen content of the supplied gases during the pre-use check.
System response time O ₂	The total system response time of the O ₂ monitor when exposed first to air and then to a gas mix with 60 % O ₂ is <30 s.
Barometric pressure compensation	Automatic

7. $\pm(9 \text{ ml} + 15 \% \text{ of actual volume})$ when set O₂ >85% and C_{static} <1.5 ml/cmH₂O and R_i <100 cmH₂O/l/s and no leakage.

8. $\pm(10 \text{ ml} + 15 \% \text{ of actual volume})$ when set O₂ >85% and C_{static} <1.5 ml/cmH₂O and R_i <100 cmH₂O/l/s and no leakage.

9. at RR < 75 b/min

10. at RR < 45 b/min

11. at RR < 75 b/min

12. at RR < 45 b/min

Monitoring	
Airway pressure	<ul style="list-style-type: none"> Range: -40 - 160 cmH₂O Inaccuracy: $\pm(1 \text{ cmH}_2\text{O} + 5 \% \text{ of actual value})$ ¹³
Gas pressure	<ul style="list-style-type: none"> Range: 0 - 7 bar Inaccuracy: $\pm 5 \% \text{ of read value}$
Signal filtering	The measured and calculated values displayed or used for control have in some cases been subjected to filtering and smoothing techniques. This is done to capture the important patterns in the data while excluding noise and make the data shown clinically relevant. These techniques are part of the inaccuracy specified in the technical data.

9.8.1 Pre-use check tests

Test	Description	Remedy if test fails
Internal	<p>Audio test and other internal tests (memory and safety-related hardware). Checks occlusion of the air inlet filter and calibrates the pressure transducer.</p>	<ul style="list-style-type: none"> Check that the air inlet filter is inserted correctly. Check the air inlet filter for occlusion. Check the date of first use for the filter. Contact a service technician.
<i>Barometer</i>	Checks the barometric pressure measured by the internal barometer.	Check the barometric pressure value in the extended menu <i>Status/System Info</i> window.
<i>Internal leakage</i>	<p>Checks for internal leakage, with test tube connected, using the inspiratory and expiratory pressure transducers. Allowed leakage: 20 ml/min at 50 cmH₂O.</p>	<p>If message <i>Leakage</i> or <i>Excessive leakage</i> appears:</p> <ul style="list-style-type: none"> check that the test tube is correctly connected, check all connections for the expiratory cassette and inspiratory channel, make sure the expiratory cassette and the inspiratory channel are clean and dry, OR contact a service technician.
<i>Turbine and gas supply</i>	<p>Checks that the O₂ supply pressure measured by the internal gas supply pressure transducer is within the specified range. Checks the turbine performance and time of operation.</p>	<p>Check that the O₂ supply pressure is within the specified range, and that the gas used is approved for the ventilator system. Refer to section Gas supply on page 134.</p>

13. PEEP accuracy may decrease for RR \geq 60 b/min together with VT \leq 20 ml.

Test	Description	Remedy if test fails
<i>Pressure transducer</i>	Calibrates and checks the expiratory pressure transducer.	<p>If the Internal leakage test passed (see above):</p> <ul style="list-style-type: none"> • check that there is no excess water in the expiratory cassette • check/replace the expiratory pressure transducer. Contact a service technician.
<i>Safety valve</i>	Checks and if necessary adjusts the opening pressure for the safety valve to $117 \pm 3 \text{ cmH}_2\text{O}$.	<p>Check the inspiratory section:</p> <ul style="list-style-type: none"> • check that the safety valve closes properly when the pre-use check is started (distinct clicking sound from the valve) • check that the safety valve membrane is correctly seated in the inspiratory pipe • check that the inspiratory pipe is correctly mounted in inspiratory section
<i>O₂ cell</i>	<p>Calibrates and checks the O₂ cell at 21 % O₂ and 100 % O₂.</p> <p>Checks if the O₂ cell is worn out.</p> <p>Because different gas mixtures are required for this test, it will not be performed if one gas is missing.</p>	<ul style="list-style-type: none"> • Check that the connected gas supply pressure and air pressure are within the specified range. • Replace the O₂ cell.
<i>Flow transducer</i>	<p>Calibrates inspiratory and expiratory flow meters.</p> <p>If O₂ is missing, no calibration of the expiratory flow transducer will be performed.</p>	<p>Check that the O₂ gas supply pressure is within the specified range.</p> <p>Check that the expiratory cassette is correctly seated in the expiratory cassette compartment.</p>
<i>Battery switch</i>	If battery modules are installed, checks battery status and switching between AC and battery power.	Check that the total remaining time for the connected battery modules are at least 10 minutes. If not, replace the discharged battery with a fully charged battery and repeat the test.
<i>Patient circuit</i>	<p>Checks the patient circuit leakage, compliance and resistance, with patient tubing connected, using the inspiratory and expiratory pressure transducers.</p> <p>Allowed leakage: 80 ml/min at 50 cmH₂O.</p> <p>Will allow the system to calculate a compensation for circuit compliance (if the leakage requirements are met).</p> <p>For ranges and accuracies, see section Patient circuit test on page 136.</p>	If the internal leakage test has passed, the leakage is located in the patient circuit. Check for leakage or replace the patient circuit.
<i>Alarm state</i>	<p>Checks that no Technical error alarms are active during the pre-use check.</p> <p>Checks that the alarm activation functions correctly.</p>	<p>Check that the cable is connected to the external system.</p> <p>Contact a service technician.</p>

9.9 Ventilatory settings

Parameter	Factory set default values (Standard configuration)		Setting range	
	Pediatric	Adult	Pediatric	Adult
Maximum apnea time in Automode (s)	3	7	3 – 15	7 - 12
Breath cycle time, SIMV (s)	1	4	0.5 - 15	1 - 15
Respiratory rate (b/min)	30	15	4 - 150	4 - 100
Circuit compensation Note: Circuit compensation is not available in NIV.	ON	ON	ON/OFF	ON/OFF
Flow trigger level in invasive modes, (l/min) Note: Flow trigger is not available in NIV.	1.6	1.6	0 - 2	0 - 2
I:E ratio	1:2	1:2	1:10 - 4:1	1:10 - 4:1
I:E ratio in backup	1:2	1:2	1:10 - 4:1	1:10 - 4:1
End inspiration (% of peak flow)	30	30	1 - 70	1 - 70
End inspiration (% of peak flow) in NIV	30	30	10 - 70	10 - 70
Inspiratory rise time (%)	5	5	0 - 20	0 - 20
Inspiratory rise time (s)	0.15	0.15	0 - 0.2	0 - 0.4
Inspiratory rise time (s) in NIV	0.2	0.4	0 - 0.2	0 - 0.4
Maximum permitted absolute pressure (cmH ₂ O)	80	100	—	—
Maximum permitted absolute pressure in NIV (cmH ₂ O)	32	32	—	—
Minute volume (l/min)	2.4	6	0.3 - 20	0.5-60
Nebulizer	OFF	OFF	ON/OFF	ON/OFF

Parameter	Factory set default values (Standard configuration)		Setting range	
	Pediatric	Adult	Pediatric	Adult
Nebulizer time (min)	10	10	5 - 30, continuous nebulization	5 - 30, continuous nebulization
O ₂ boost level (%)	30	30	0 - 79	0 - 79
O ₂ concentration (%)	40	40	21 - 100	21 - 100
PEEP (cmH ₂ O)	5	8	1 - 50	1 - 50
PEEP in NIV (cmH ₂ O)	5	5	2 - 20	2 - 20
P _{high} (cmH ₂ O)	15	15	2 - 50	2 - 50
Pressure trigger level (cmH ₂ O)	—	—	-1 - -20	-1 - -20
Pressure level above PEEP (cmH ₂ O)	10	15	0 - 79	0 - 99
Pressure level above PEEP in NIV (cmH ₂ O)	5	5	0 - 60	0 - 60
Pressure level above PEEP in backup (cmH ₂ O)	10	15	5 - 79	5 - 99
Pressure level above PEEP in NIV backup (cmH ₂ O)	5	5	5 - 60	5 - 60
PS above PEEP in Bi-Vent/APRV (cmH ₂ O)	0	0	0 - 79	0 - 99
PS above P _{high} in Bi-Vent/APRV (cmH ₂ O)	0	0	0 - 78	0 - 98
Respiratory rate in backup	30	15	4 - 150	4 - 100
SIMV frequency (b/min)	20	5	1 - 60	1 - 60
T _{high} (s)	1	2	0.2 - 30	0.2 - 30
T _i (s)	0.5	0.9	0.1 - 5	0.1 - 5
T _i in backup (s)	0.5	0.9	0.1 - 5	0.1 - 5
Tidal volume (ml)	80	400	20 - 350	100 - 2000
Tidal volume in backup (ml)	80	400	20 - 350	100 - 2000

Parameter	Factory set default values (Standard configuration)		Setting range	
	Pediatric	Adult	Pediatric	Adult
T _{pause} (%)	10	10	0 – 30	0 – 30
T _{pause} (s)	0	0	0 - 1.5	0 - 1.5
TPEEP (s)	1	2	0.1 - 10	0.1 - 10
Weight (kg)	—	—	2 - 100	10 - 250

9.10 Alarms

9.10.1 Alarm limits

Parameter	Factory set default		Setting range		Audio Off (only for NIV)
	Pediatric	Adult	Pediatric	Adult	
Airway pressure, upper limit (cmH ₂ O) ¹⁴	40	40	16 - 90	16 - 100	—
Airway pressure, upper limit (cmH ₂ O) in NIV ¹⁵	25	25	16 - 70	16 - 70	No
Apnea time to alarm (s)	10	20	2 - 45	15 - 45	No
End expiratory pressure, upper limit (cmH ₂ O)	15	15	1 - 55	1 - 55	Yes
End expiratory pressure, lower limit (cmH ₂ O) ¹⁶	2	2	0 - 47	0 - 47	Yes
Expired minute volume, lower limit (l/min)	2	5	0.01-20	0.5 - 40	Yes
Expired minute volume, upper limit (l/min)	5	40	0.02 - 30	1 - 60	Yes
Respiratory rate, lower limit (b/min)	20	5	1 - 159	1 - 159	Yes
Respiratory rate, upper limit (b/min)	50	30	2 - 160	2 - 160	Yes
O ₂ concentration, lower alarm limit (vol%)	Set value -5 vol% ¹⁷ or ≤18 vol%		—	—	No
O ₂ concentration, upper alarm limit (vol%)	Set value +5 vol% ¹⁸		—	—	No
O ₂ gas supply	<2.0 kPa x 100 or >6.0 kPa x 100		—	—	—
High continuous pressure	Obstruction leading to constant high airway pressure (>PEEP +15 cmH ₂ O) during: <ul style="list-style-type: none"> > 2 breaths or 5 s, whichever is greater, 15 ±1.5 s if less than 2 breaths are triggered) 		—	—	No

14. If P_{aw} rises 6 cmH₂O above the set limit or if system pressure exceeds 117 ±5 cmH₂O, the safety valves opens.

15. If P_{aw} rises 6 cmH₂O above the set limit or if system pressure exceeds 117 ±5 cmH₂O, the safety valves opens.

16. Setting the alarm limit to 0 (zero) is equivalent to turning off the alarm.

17. When the set O₂ concentration is higher than 90 %, the O₂ concentration low alarm is set to 85%.

18. When the set O₂ concentration is higher than 90 %, the O₂ concentration high high alarm is deactivated.

Always make sure relevant values are set.

Refer to section Conditions leading to default alarm settings on page 110.

9.10.2 Autaset alarm limits - controlled modes only

Autaset alarm limits - controlled modes only	
High airway pressure	Mean peak pressure +10 cmH ₂ O
Expiratory minute volume (upper alarm limit)	Mean expiratory minute volume + 50 %
Expiratory minute volume (lower alarm limit)	Mean expiratory minute volume - 50 %
Respiratory rate (upper alarm limit)	Mean respiratory rate + 40 %
Respiratory rate (lower alarm limit)	Mean respiratory rate - 40 %
End expiratory pressure (upper alarm limit)	Mean end expiratory pressure + 5 cmH ₂ O
End expiratory pressure (lower alarm limit)	Mean end expiratory pressure - 3 cmH ₂ O

9.10.3 Alarms miscellaneous

Alarms miscellaneous	
Audio pause (Alarm silenced)	Two-minute silence
Alarm sound level	<p>The alarm sound level can be set in 10 steps (to between 60-82 dB(A) ±6 dB(A))</p> <ul style="list-style-type: none"> • High priority alarm: A sequence of 3 + 2 beeps, short pause, 3 + 2 beeps, long pause • Medium priority alarm: A sequence of 3 beeps, long pause • Low priority alarm: A sequence of 2 beeps, long pause

9.11 Functions in ventilation modes

Functions in ventilation modes	
Maximum inspiration time	<ul style="list-style-type: none"> • Pediatric: 1.5 s • Adult: 2.5 s
NIV disconnection flow	<p>Pediatric</p> <ul style="list-style-type: none"> • Low flow: 7.5 l/min • High flow: 15 l/min • Disabled: the ventilator system will continue to deliver assist even when leakage is excessive. <p>Adult</p> <ul style="list-style-type: none"> • Low flow: 7.5 l/min • High flow: 40 l/min • Disabled: the ventilator system will continue to deliver assist even when leakage is excessive.

9.12 Trends

Peak airway pressure	P_{peak}
Pause airway pressure	P_{plat}
Mean airway pressure	P_{mean}
Positive end expiratory pressure	PEEP
Spontaneous breaths per minute	RR_{sp}
Respiratory rate	RR
Spontaneous expiratory minute volume	$MV_{e\ sp}$
Inspired minute volume	MV_i
Expired minute volume	MV_e
Leakage (%)	Leakage
Inspired tidal volume	VT_i
Expired tidal volume	VT_e
End expiratory flow	$Flow_{ee}$
Measured oxygen concentration	$O_2\ conc.$
Dynamic compliance	C_{dyn}
Static compliance	C_{static}
Inspiratory resistance	R_i
Expiratory resistance	R_e
Work of breathing, ventilator	WOB_{vent}
Work of breathing, patient	WOB_{pat}
Elastance	E
P 0.1	P 0.1
Shallow Breathing Index	SBI
Ratio of expired tidal volume to predicted body weight	VT/PBW
Switch to backup (/minute)	Backup Σ
Backup (%/min)	Backup %

9.13 Logs

9.13.1 Event log

The following events are logged:

- Activation of alarms
- Calibration results
- Alarm limit changes
- Ventilator settings
- Apnea periods
- Pre-use checks
- Manual breath
- O₂ boost
- Inspiratory hold
- Expiratory hold
- Activation/deactivation of circuit compensation
- Turning backup on/off
- Operator initiated return from backup to supported ventilation
- Automatic return from backup to supported ventilation
- Disconnection and reconnection of patient
- Activation/deactivation of nebulization
- Deactivation of backup ventilation

9.13.2 Diagnostic log

The following items are logged:

- Technical information
- Test results
- Service records
- Software installation
- Configuration information

9.14 Service

WARNINGS!

- Preventive maintenance must be performed by authorized personnel at least once a year or after every 5000 hours of operation. The time to next preventive maintenance is displayed from the extended menu, *SYSTEM STATUS*/General window.
- Service, repair and installation must be performed by Maquet authorized personnel only.
- Service and settings should only be used without a patient connected to the ventilator system.

CAUTIONS:

- All technical documentation is available for use by Maquet authorized personnel.
- Information regarding assembling the system or options to obtain a proper mechanical assembly is available from Maquet.
- Original parts from Maquet must be used.
- Disconnect the mains power cable from the outlet to isolate the ventilator system from mains power.

9.15 Aerogen nebulizer

9.15.1 Aerogen Pro nebulizer

Aerogen Pro nebulizer	
Weight	Approximate 25 g
Dimensions	W 50 x L 50 x H 45 mm
Particle size, graph	Representative particle size distribution for Salbutamol (Albuterol) as per EN 13544-1.

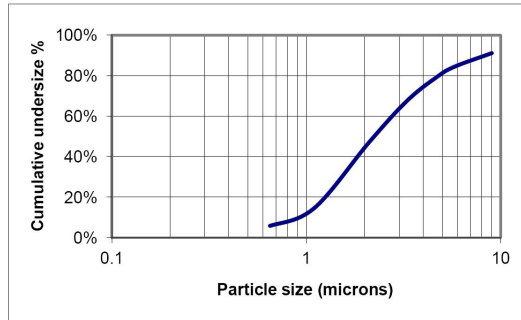

As measured with the Anderson Cascade Impactor:

1 - 5 μm .

Average tested

3.1 μm

As measured with the Marple 298 Cascade Impactor:

1.5 - 6.2 μm .

Average tested

3.9 μm

Flow rate >0.2 (average: ~0.4) ml/min

Max volume, medication cup 10 ml

Residual volume <0.1 ml for 3 ml dose

Control cable 1.8 m

Aerosol output rate 0.24 ml/min with starting dose 2 ml

Aerosol output 1.08 ml with starting dose 2 ml

Medication temperature The temperature of the medication will not rise more than 10°C (18°F) above ambient temperature during normal use.

Lifetime

One year based on a typical usage profile of four treatments per day and one sterilization per week where the device is assumed to be in service for 50 % of the time. If this service pattern is exceeded, it may reduce the life of the product.

9.15.2 Aerogen Solo nebulizer

Aerogen Solo nebulizer	
Weight	Approximate 13.5 g
Dimensions	W 48 x L 25 x H 67 mm
Particle size, graph	Representative particle size distribution for Salbutamol (Albuterol) as per EN 13544-1.

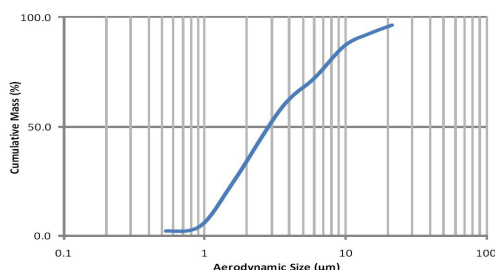

As measured with the Anderson Cascade Impactor:	
• Specification range	1 - 5 µm.
• Average tested	3.1 µm

As measured with the Marple 298 Cascade Impactor:	
• Specification range	1.5 - 6.2 µm.
• Average tested	3.9 µm

Flow rate	>0.2 (average: ~0.38) ml/min
Max volume, medication cup	6 ml
Residual volume	<0.1 ml for 3 ml dose
Control cable	1.8 m
Aerosol output rate	0.30 ml/min with starting dose 2 ml
Aerosol output	1.02 ml with starting dose 2 ml
Medication temperature	The temperature of the medication will not rise more than 10°C (18°F) above ambient temperature during normal use.

Lifetime	<ul style="list-style-type: none"> • Intermittent use a maximum of 28 days based on a typical usage profile of four treatments per day. • Continuous use a maximum of 7 days. <p>Do not exceed the recommended usage time.</p>
----------	--

9.16 Communication/interface

Communication/interface	
Serial ports	<p>Isolated</p> <p>RS-232C. For data communication via the Servo Communication Interface (SCI)</p> <p>Information regarding connector wiring is available from Maquet.</p>
Servo Communication Interface (SCI)	A protocol for data communication with external devices
Alarm output connection (option)	<p>Isolated</p> <p>4-pin modular connector for communication of all active alarms</p> <p>Switching capability: Max 40V DC, Max 500 mA, Max 20 W</p> <p>Information regarding connector wiring is available from Maquet.</p>
Data Transfer via USB port	<p>Non-isolated</p> <p>For transfer of trends, logs, screen shots and recordings to a USB memory stick and for service purposes.</p>
Ethernet port	<p>Isolated</p> <p>The network connection (LAN) port is for service use, and should only be used by personnel trained and authorized by Maquet.</p>

Connection of the ventilator system to other equipment through the communication interfaces, forming a medical electrical system, could result in previously unidentified risks to patient, users or third parties.

The responsible organization should identify, analyze, evaluate and control these risks.

Subsequent changes to the medical electrical system could introduce new risks and require additional analysis.

Changes to the medical electrical system include configuration changes, connection of additional items, disconnection of items, update or upgrade of connected equipment.

9.17 Accessories

Mobile cart (option)

Weight	15.0 kg
Dimensions	W 647 x L 547 x H 860 mm
Preventive maintenance interval	5000 running hours

Humidifier holder (option)

Weight	0.5 kg
Dimensions	W 76 x L 125 x H 140
Maximum load	12 kg

Support arm 179 (option)

Weight	2.5 kg
Dimensions	Length 900 mm
Maximum load	<ul style="list-style-type: none"> • 1 kg at 180° • 1.5 kg at 90° • 3 kg at 45°

Refer to Support arm 179 Installation Instructions.

Note: When the knob on the support arm is loosened it also releases the lock to the column.

Water bag/IV pole (option)

Weight	0.4 kg
Dimensions	W 148 x L 26 x H 1007
Maximum load	1.5 kg

Gas cylinder restrainer kit (option)

Make sure that the gas cylinder restrainer straps are placed on the middle of the gas cylinders.

Weight	0.5 kg
Dimensions	Upper: W 104 x L 65 x H 48 Lower: W 106 x L 162 x H 76
Maximum load	Two 4.5-liter bottles

Shelf base (option)

Make sure that the shelf base is securely fixed on the table or shelf.

Weight	3.0 kg
Dimensions	W 340 x L 270 x H 43

Y piece holder (option)

Dimensions	W 26 x L 52 x H 46
------------	--------------------

Cable holder for handle (option)

Weight	0.1 kg
Dimensions	W 138 x L 92 x H 155
Maximum load	10 kg

Other accessories (option)

Expiratory heater, Servo Duo Guard	Refer to the Expiratory heater, Servo Duo Guard User's Manual.
Servo Duo Guard	Refer to the Servo Duo Guard User's Manual.
Servo Guard	Refer to the Servo Guard User's Manual.

Refer to System Flow Chart, SERVO-air for information regarding use of accessories to be used with the ventilator system.

9.18 Health and Environment

9.18.1 Pollution control

This product complies with environmental protection use period as defined in People's Republic of China Electronic Industry Standard SJ/T11364-2014.



Toxic or hazardous substances will not leak or mutate under normal operating conditions for 50 years.

9.18.2 Hazardous substances

The following table shows the names and contents of toxic or hazardous substances in this product as defined in People's Republic of China Electronic Industry Standard SJ/T11364-2014.

Parts	Hazardous substances					
	Pb	Hg	Cd	Cr ⁶⁺	PBB	PBDE
Metal parts	0	0	0	0	0	0
Plastic and polymeric parts	0	0	0	0	0	0
Electrical components	0	0	0	0	0	0
LCD display	0	0	0	0	0	0

0: Indicates that this toxic or hazardous substance contained in all of the homogeneous materials for this part is below the limit and meets the requirement in GB/T 26572-2011.

X: Indicates that this toxic or hazardous substance contained in at least one of the homogeneous materials used for this part is above the limit requirement in GB/T 26572-2011.

9.19 UDI label

UDI Label	
Unique Device Identification number	Global standard for identifying Medical Equipment, example: (01)07325710000007(11)140625(21)01311141
Application Identifier (AI)	Each UDI number can be divided into several parts, each referred to by their AI number '#'. (01) GTIN - Global Trade Item Number (241) Part number (10) Batch no. (11) Manufacturing date (YYMMDD) (17) Exp. date (YYMMDD) (20) Revision (21) Serial number (30) Count of items
The GTIN consists of four parts:	0 732571 000021 2
a. Package level	a b c d
b. GS-1 company prefix	
c. Item reference	
d. Check digit	

9.20 Technical description

The technical description is intended for the responsible organization and service personnel.

Topic	Information
Signal filtering	Refer to section Monitoring on page 139.
Detachable parts	Refer to section Gas flow through the patient unit on page 21.
Start and end the inspiratory phase	Refer to chapter Ventilation modes on page 55.
Automatic check of alarm system.	Refer to section Pre-use check on page 38.
Measurement uncertainty for disclosed tolerances	Refer to sections Inspiratory channel on page 137, Expiratory channel on page 138 and Monitoring on page 139.
Safe operation	Refer to section Safety guidelines on page 8.
Transport and storage	Refer to section Transport on page 36.
Measures or conditions for installing the ventilator system.	Information regarding installation is available from Maquet.
Operation overview	Refer to chapter Operation overview on page 37.
Safety signs and symbols <ul style="list-style-type: none"> • Marking on equipment • Consult accompanying documents • Mechanical stability • Protective packaging 	Refer to sections Symbols on patient unit on page 19, Symbols on user interface on page 32 and Symbols on accessories and packaging on page 34.
Identification of the ventilator system and software version	Refer to sections SERVO-air Ventilator System v2.1 on page 1 and Version and configurations on page 14.
Power sources	Refer to section System on page 132.
IP classification	Refer to section System on page 132.
Applied part — type of classification	Refer to sections Symbols on accessories and packaging on page 34 and System on page 132.
Mode of operation	Refer to section System on page 132.
Fuses	Refer to sections Operation overview on page 37 and System on page 132.
External pressure source	Refer to section Ventilator system on page 134.
Modification of the ventilator system	Do not modify or remove any original parts.
Service and installation <ul style="list-style-type: none"> • Qualifications for service personnel • Replacement of parts • Installation requirements • Documentation 	Refer to section Service on page 149.
Isolate from mains power	Isolate the ventilator system from mains power by disconnecting the mains power cable from the outlet.
Alarms preset	Refer to section Alarms on page 127.
Technical data	Refer to chapter Technical data on page 131.
System overview	Refer to chapter System Overview on page 15.

10 Index

A

Accessories

- cable holder for handle 154
- expiratory heater, Servo Duo Guard 154
- gas cylinder restrainer kit 153
- humidifier holder 153
- mobile cart 153
- Servo Duo Guard 154
- Servo Guard 154
- shelf base 153
- water bag/IV pole 153
- Y piece holder 153

Aerogen nebulizer unit 101, 105, 105

Aerogen nebulizers

- adding medication 104
- assemble 102
- function test 103

Aerogen Pro nebulizer

- aerosol output 150
- aerosol output rate 150, 151
- control cable 150
- dimensions 150
- flow rate 150
- lifetime 150
- medication cup 150
- medication temperature 150
- particle size 150
- residual volume 150
- specification range 150, 150

Aerogen Solo nebulizer

- aerosol output 151
- average tested 150, 150, 151, 151
- continuous nebulization 106
- control cable 151
- dimensions 151
- flow rate 151
- lifetime 151
- medication cup 151
- medication temperature 151

particle size 151

residual volume 151

specification range 151, 151

weight 150, 151

Aerosol output

Aerogen Pro nebulizer 150, 150, 151

Aerogen Solo nebulizer 151

Airway pressure 140

Alarm limits

default values 145

parameters 145

setting range 145

Alarm output connection 14, 122

Alarms

default settings 110

handling 111

high priority 115, 115, 120

indication 111

low priority 119, 121

medium priority 117, 121

sound level 43

Ambient pressure 135

Apnea

management 98

maximal time 90

time 90, 98

Atmospheric pressure 133, 133

Audio off 145

Automode 71

Average tested

Aerogen Pro nebulizer 150, 150

Aerogen Solo nebulizer 151, 151

B

Backup ventilation

deactivating 100

trends 99

Barometric pressure compensation

monitoring 139

Battery

- backup 133
- disposal 133
- lifetime 133
- warnings 12
- Bias flow during expiration 138
- Biomed 124
- Bi-Vent/APRV 63
- Breathing parameters
 - default values 142, 144
 - parameters 144
 - setting range 144
- BTPS 135
- C**
- Cable holder for handle
 - dimensions 154
 - maximum load 154
 - weight 154
- Cautions
 - general 9
 - power supply 11
- Cleaning & Maintenance 7
- Communication/Interface
 - alarm output connection 152
 - ethernet port 152
 - SCI 152
 - serial ports 152
 - USB port 152
- Compensation
 - circuit 94, 135
 - leakage 94
- Compliance 136
- Configuration
 - Biomed code 128
 - set date 128
 - set time 128
 - view 53
- Conical fittings 134
- Connection standards 134
- Continuous nebulization 106
- Control cable
 - Aerogen Pro nebulizer 150

- Aerogen Solo nebulizer 151

D

- Default alarm settings 110

Dimensions

- cable holder for handle 154
- gas cylinder restrainer kit 153
- humidifier holder 153, 153
- mobile cart 153, 153
- shelf base 153, 153
- support arm 153
- ventilator 134
- water bag/IV pole 153
- Y piece holder 153

- Disclaimers 7

- Disconnection/Suction 95

E

- EMC 132

- End inspiration 86

- Essential performance 136

Expiratory

- flow measurements 138
- heater, Servo Duo Guard 154
- hold 92
- minute volume 139
- tidal volume 139

Expiratory channel

- airway pressure 140
- barometric pressure compensation 139
- bias flow during expiration 138
- expiratory flow measurements 138
- internal compressible factor 138
- O₂ concentration 139
- PEEP regulation 138
- PEEP setting range 138
- pressure drop 138
- respiratory rate 139
- supply pressure 140
- system response time O₂ 139

- Export & delete 53

F

Flow rate

- Aerogen Pro nebulizer 150
- Aerogen Solo nebulizer 151

Functions

- circuit compensation 94
- disconnection/suction 95
- leakage compensation 94
- manual breath 91
- max. inspiration time 146
- nebulization 92
- NIV disconnection flow 146
- O2 boost level 93
- static measurements 92

G

Gas

- exhaust port 134

Gas cylinder restrainer kit

- dimensions 153
- maximum load 153
- weight 153

Gas supply

- connection standards 134

General

- caution 9
- important 10
- note 11
- warning 8

H

High priority alarms 115, 120

Holders

- cable holder for handle 154
- gas cylinder restrainer kit 153
- humidifier holder 153
- shelf base 153
- water bag/IV pole 153
- Y piece 153

I

I:E ratio 85, 135

Important

- general 10

Ingress protection 132

Inlet

- pressure 135

Inspiration time 86

Inspiratory

- hold 92
- rise time 87
- tidal volume 139

Intended use 6

Internal

- compressible factor 138

L

Leakage 135

Lifetime

- Aerogen Pro nebulizer 150
- Aerogen Solo nebulizer 151

Logs

- event log 148, 148

Low priority alarms 119, 121

Lowest pressure in patient circuit 133

M

Maneuvers

- manual breath 91
- static measurements 92

Maximum

- inspiration time 146

Maximum load

- cable holder for handle 154
- gas cylinder restrainer kit 153
- humidifier holder 153
- support arm 153
- water bag/IV pole 153

Media

- recording waveforms 52
- saving screenshots 51

Medication cup

- Aerogen Pro nebulizer 150
- Aerogen Solo nebulizer 151

Medication temperature

Aerogen Pro nebulizer 150

Aerogen Solo nebulizer 151

Medium priority alarms 117, 121

Minute volume 84

Mobile cart

dimensions 153

preventive maintenance interval 153

weight 153

Modes

Automode 71

Bi-Vent/APRV 63

Pressure Control 57

Pressure Regulated Volume Control 59

Pressure Support/CPAP 65

SIMV 74

Volume Control 61

Volume Support 68

Module

handling 22

Monitoring

expiratory minute volume 139

expiratory tidal volume 139

inspiratory tidal volume 139

N

Nebulization 101, 104, 106

Nebulization

continuous 106

on/off 104

Nebulizer

Pro 101, 105

Solo 101, 105

use guidelines 102, 102

NIV

Pressure Control 80

Pressure Support 81

NIV disconnection flow 146

NIV disconnection function

edit 126

Noise 132

Non invasive ventilation 78

Non operating conditions

atmospheric pressure 133

relative humidity 133

temperature 133

Notes

general 11

power supply 12

Numerical values 50

O

O₂

boost function 93

cell adjustment 107

O₂ boost level 93

O₂ cell adjustment 107

O₂ concentration 84, 139

Operating conditions 133

Operating conditions

atmospheric pressure 133

lowest pressure in patient circuit 133

relative humidity 133

temperature range 133

P

Particle size

Aerogen Pro nebulizer 150

Aerogen Solo nebulizer 151

Patient category 40, 40, 132

Patient category

change 40

select 40

set 40, 40

Patient circuit 24

Patient circuit

10 mm dual heat 28

10 mm single heat 27

15-22 mm single heat 25

22 mm dual heat 26

Patient circuit test 39

Patient circuit test

compliance 136

expiratory resistance 136

- inspiratory resistance 136
 - Patient data
 - deleting 53
 - enter 31
 - exporting 53
 - saving 51
 - Patient system connectors
 - conical fittings 134
 - gas exhaust port 134
 - pressure line connector 134
 - Patient unit 18
 - Patient unit
 - on/off switch 18
 - PBW 91
 - PEEP regulation 138
 - PEEP setting range 138
 - Power supply
 - cautions 11
 - external 12V DC 133
 - notes 12
 - range 133
 - warnings 11
 - Predicted body weight 91
 - Pressure Control 57
 - Pressure drop 138
 - Pressure level 84
 - Pressure line connector 134
 - Pressure Regulated Volume Control 59
 - Pressure Support/CPAP 65
 - Pre-use check 38, 39, 135, 140
 - Pre-use check
 - start 39
 - Pre-use check test
 - alarm output connection 14
 - Preventive maintenance interval
 - mobile cart 153
 - Previous mode 97
- R**
- Relative humidity 133, 133
 - Remote Services 129
 - Residual volume
 - Aerogen Pro nebulizer 150
 - Aerogen Solo nebulizer 151
 - Respiratory rate 139
 - Room temperature 135
- S**
- Safety scales 31, 41
 - Select
 - ventilation 41
 - Service 7, 128, 149
 - Servo Duo Guard 154
 - Servo Guard 154
 - Set
 - alarm limits 42
 - patient category 40, 40
 - Settings 135
 - Settings
 - apnea time 90
 - end inspiration 86
 - I:E ratio 85
 - inspiratory rise time 87
 - minute volume 84
 - O₂ concentration 84
 - pressure level 84
 - SIMV breath cycle time 90
 - tidal volume 84
 - trigger 88
 - Shelf base
 - dimensions 153
 - weight 153
 - Shortcuts 31
 - SIMV breath cycle time 90
 - Specification range
 - Aerogen Pro nebulizer 150, 150
 - Aerogen Solo nebulizer 151, 151
 - Standard conditions
 - ambient pressure 135
 - BTPS 135
 - circuit compensation 135
 - I:E 135
 - inlet pressure 135
 - pre-use check 135

- room temperature 135
- settings 135
- STPD 135
- ventilatory frequency 135

Standards

- Ventilator 132

Start

- pre-use check 39
- ventilation 44

Startup configuration 126

Stop

- ventilation 44

Storage temperature 133

STPD 135

Suction

- closed suctioning 97
- open suctioning 95

Supply pressure 140

Support arm

- dimensions 153
- maximum load 153
- weight 153

Symbols

- accessories and packaging 34
- patient unit 19
- user interface 32

System

- EMC 132
- ingress protection 132
- noise 132

System response time O₂ 139

System status 54

T

Technical alarms

- high priority alarms 115
- low priority alarms 119, 121
- medium priority alarms 117, 121

Technical error alarms 120

Temperature range 133

Temporary O₂ increase
edit 127

Tidal volume 84

Transport 36

Transport

- before transport 36
- during transport 36

Trends 50, 147

Triggering

- pneumatic trigger 88

U

User interface 29

User interface

- interactive areas 29
- light frame 29
- navigating 30

V

Ventilation

- select 40, 41
- start 44
- stop 44

Ventilator 16

Ventilator

- configuration 53
- dimensions 134
- weight 134

Ventilatory frequency 135

Views

- Advanced 47
- Basic 46
- Distance 48
- Family 48
- Loops 47

Volume Control 61

Volume Support 68

W

Warnings

- battery 12
- fire hazard 13
- general 8
- power supply 11

Water bag/IV pole
 dimensions 153
 maximum load 153
 weight 153

Waveforms
 displaying 49
 scaling 49

Weight
 Aerogen Pro nebulizer 150, 150
 Aerogen Solo nebulizer 151, 151
 cable holder for handle 154
 gas cylinder restrainer kit 153
 humidifier holder 153
 mobile cart 153
 shelf base 153
 support arm 153
 ventilator 134
 water bag/IV pole 153

Y

Y piece holder
 dimensions 153

MAQUET
GETINGE GROUP

Manufacturer: Maquet Critical Care AB
Röntgenvägen 2
171 54 Solna, Sweden
Phone: +46 (0) 10 335 73 00
www.maquet.com

For local contact:
Please visit our website
www.maquet.com



GETINGE GROUP

Getinge Group is a leading global provider of innovative solutions for operating rooms, intensive-care units, hospital wards, sterilization departments, elderly care and for life science companies and institutions. With a genuine passion for life we build quality and safety into every system. Our unique value proposition mirrors the continuum of care, enhancing efficiency throughout the clinical pathway. Based on our first-hand experience and close partnerships, we are able to exceed expectations from customers – improving the every-day life for people, today and tomorrow.

SERVO-air Ventilator System v2.1

User's Manual